

36621-MI

Battery Low Voltage Protection Module

Non-isolated, DC voltage disconnect relay module for preventing over discharge of batteries. Adjustable cutoff and reconnect. Relay opens when Input voltage drops below set limit, closes when input reaches the adjustable reconnect value
Rated: 12-36V Batteries (Max Input <80V)
Contact Rating: 20A Max @ 14V
Output Voltage: same as Input voltage
Control Accuracy: 0.1V
Power consumption: <1.5W
SQ: 1-5/8" H: 3/4" WT: .07

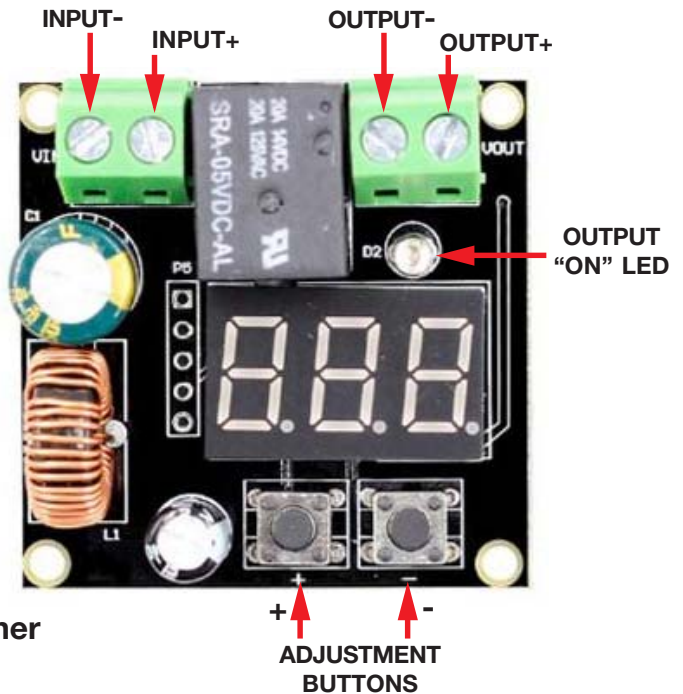

NOTE: Non-Isolated
Input - and Output - are internally connected together

Instructions:

Practice This.

Set Low Cutoff Voltage

+ Button: Press until Display Flashes the pre-set set value (Gotta be quick here or unit will add 0.1 to reading)
Use + Button to add 0.1V or - Button to subtract 0.1V at each press
After ~4sec, the unit will revert to normal display (Output Voltage).

Set Reconnect Voltage

NOTE: Important!!

You set a value that is Added to the Low Voltage Cutoff value;
Ex: if Cutoff is set for 11.0V and you want to Reconnect load at 13.5V:
You set this value to 2.5V (11 + 2.5=13.5)

DO NOT set the Reconnect Voltage same or close to Cutoff Voltage as any loading may cause a voltage drop and the relay will oscillate on/off rapidly (Chatter) and could damage load or module.

-Button: Press until Display Flashes the pre-set set value (Gotta be quick here or unit will subtract 0.1 from reading)
Use + Button to add 0.1V or - Button to Subtract 0.1V at each press
After ~4sec, the unit will revert to normal display (Output Voltage).

Information including Drawings, Schematics, Links and Code (Software) Supplied or Referenced in this Document is supplied by MPJA inc. as a service to our customers and accuracy or usefulness is not guaranteed nor is it an Endorsement of any particular part, supplier or manufacturer. Use of information and suitability for any application is at users own discretion and user assumes all risk.

Information Subject to Change Without Notice
All rights are retained by the respective Owners/Author(s)



MARLIN P. JONES & ASSOC., INC.

P.O. Box 530400 Lake Park, FL 33403
800-652-6733 FAX 561-844-8764
WWW.MPJA.COM