

32361-MP

State of the Art Smoke & Gas Sensor Module for Microcontrollers

MQ-2 sensor coupled with a simple adjustable comparator circuit using a LM393 IC. Detects Smoke, Hydrogen, Methane, Propane, Butane & Alcohol in the air. Designed to interface to a Arduino or other micro controllers. Freeware available through www.arduino.cc/en and other web sites.

Power: 5VDC

Outputs: TTL Compatible Digital & Sensor Direct Analog

4 Pin .1in. Pitch Header pins for Power & Output

LEDs for Output and Power status indication.

Detection Zone: 200-5000 Propane

300-5000 Butane & Hydrogen

5000-20000 Methane

100-2000 Alcohol

Response Time: <10Sec. Recovery Time: <30Sec.

Environmental: -20 to +50C, Humidity; <95%, <21% Oxygen

L: 1-1/4" W: 13/16" H: 7/8" WT: .02

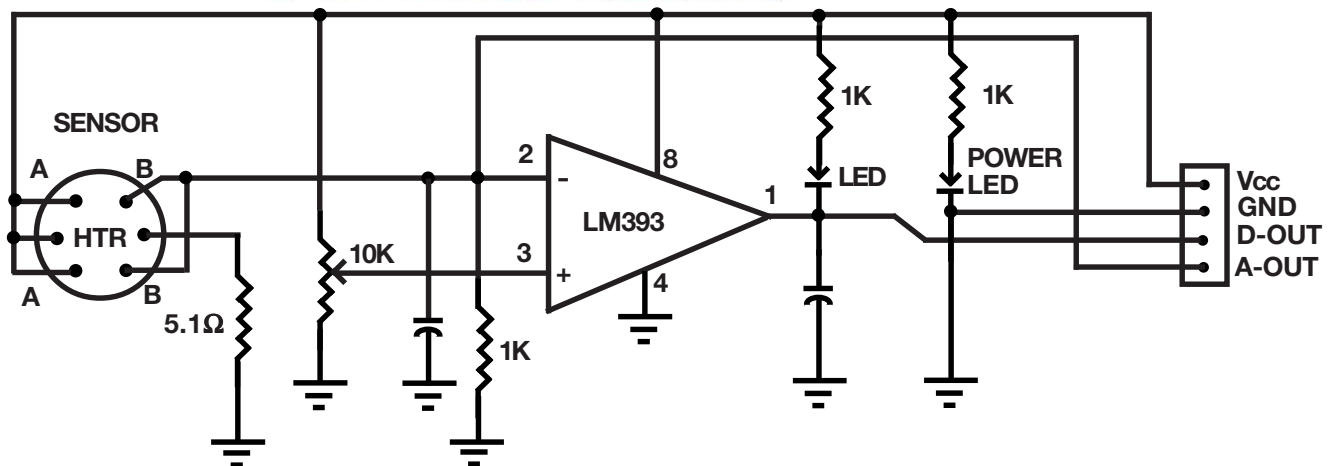
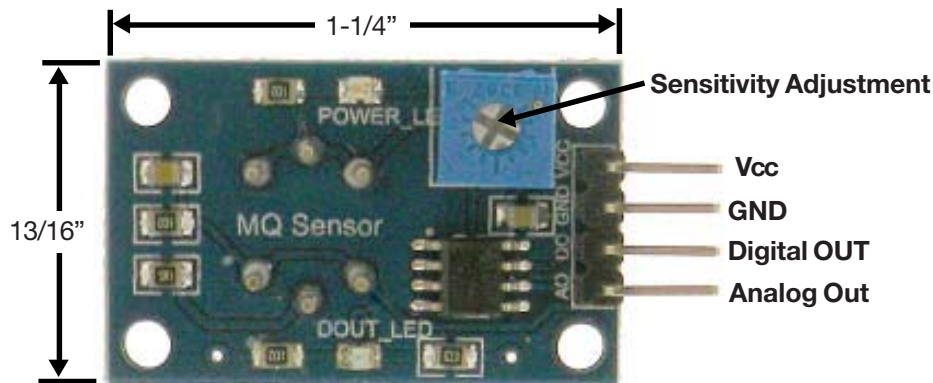

Information obtained from or supplied by Mpja.com or Marlin P. Jones and Associates inc. is supplied as a service to our customers and accuracy is not guaranteed nor is it definitive of any particular part or manufacturer. Use of information and suitability for any application is at users own discretion and user assumes all risk.



MARLIN P. JONES & ASSOC., INC.

P.O. Box 530400 Lake Park, FL 33403

800-652-6733 FAX 561-844-8764

WWW.MPJA.COM