

# TC9203P/F

## PLL MOTOR CONTROL FOR FDD

TC9203P/F are C<sup>2</sup>MOS LSI designed for controlling the motor of especially for Disk Spindle Drive (FDD). 8-bit D/A converter system has been employed for each of the speed control system (AFC) and the phase control system (APC) and realize a wide reduction of external parts and free adjustment motor control system.

- Crystal can be used up to 8MHz, and crystal reference dividing frequency selected from three position of 1/5, 1/6 and 1/12 correspond to 8, 5 and 3.5 inch FDD.
- Lock range can be selected from two position of 1/20 and 1/27.
- External oscillator makes possible fine adjustment of speed.
- Lock detection output and reverse rotation signal output are provided.
- Surface mount is available with TC9203F.

## MAXIMUM RATINGS (Ta=25°C)

CHARACTERISTIC	SYMBOL	RATING	UNIT
Supply Voltage	V <sub>DD</sub>	-0.3~7.0	V
Input Voltage	V <sub>IN</sub>	-0.3~V <sub>DD</sub> +0.3	V
Power Dissipation	P <sub>D</sub>	300	mW
Operating Temperature	T <sub>opr</sub>	-30~75	°C
Storage Temperature	T <sub>stg</sub>	-55~125	°C

## PIN CONNECTIONS

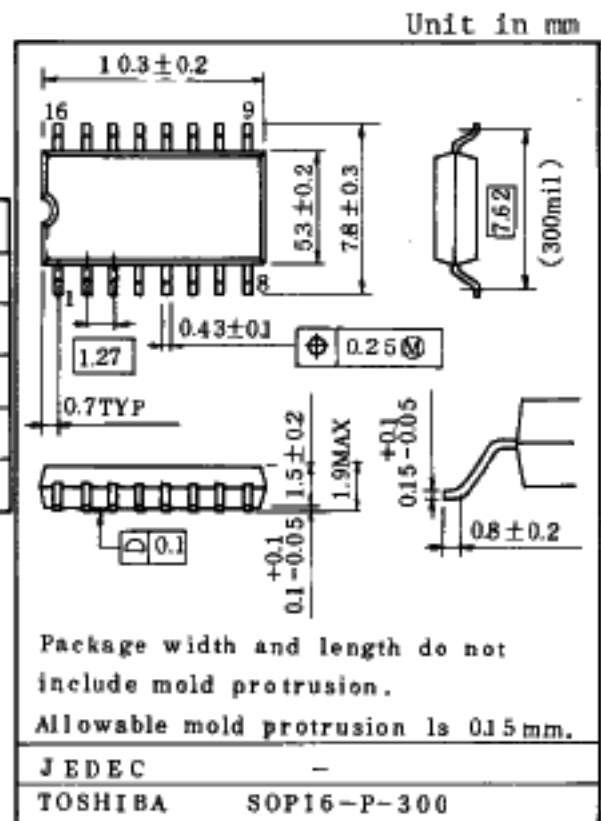
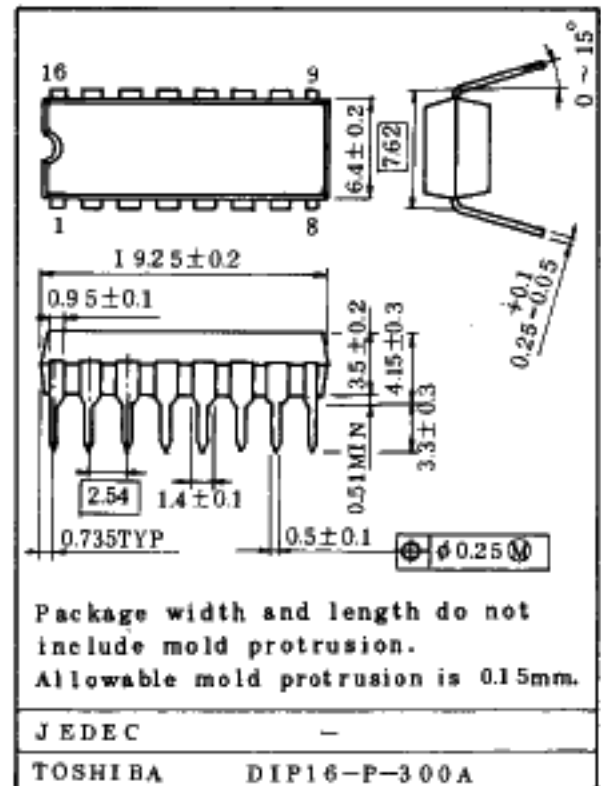
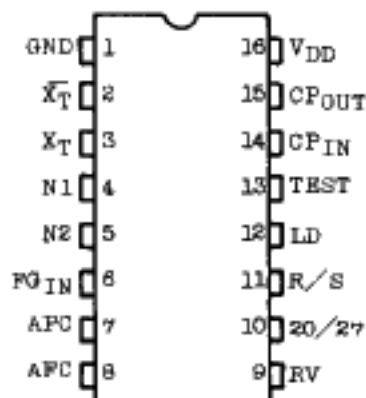

BLOCK DIAGRAM

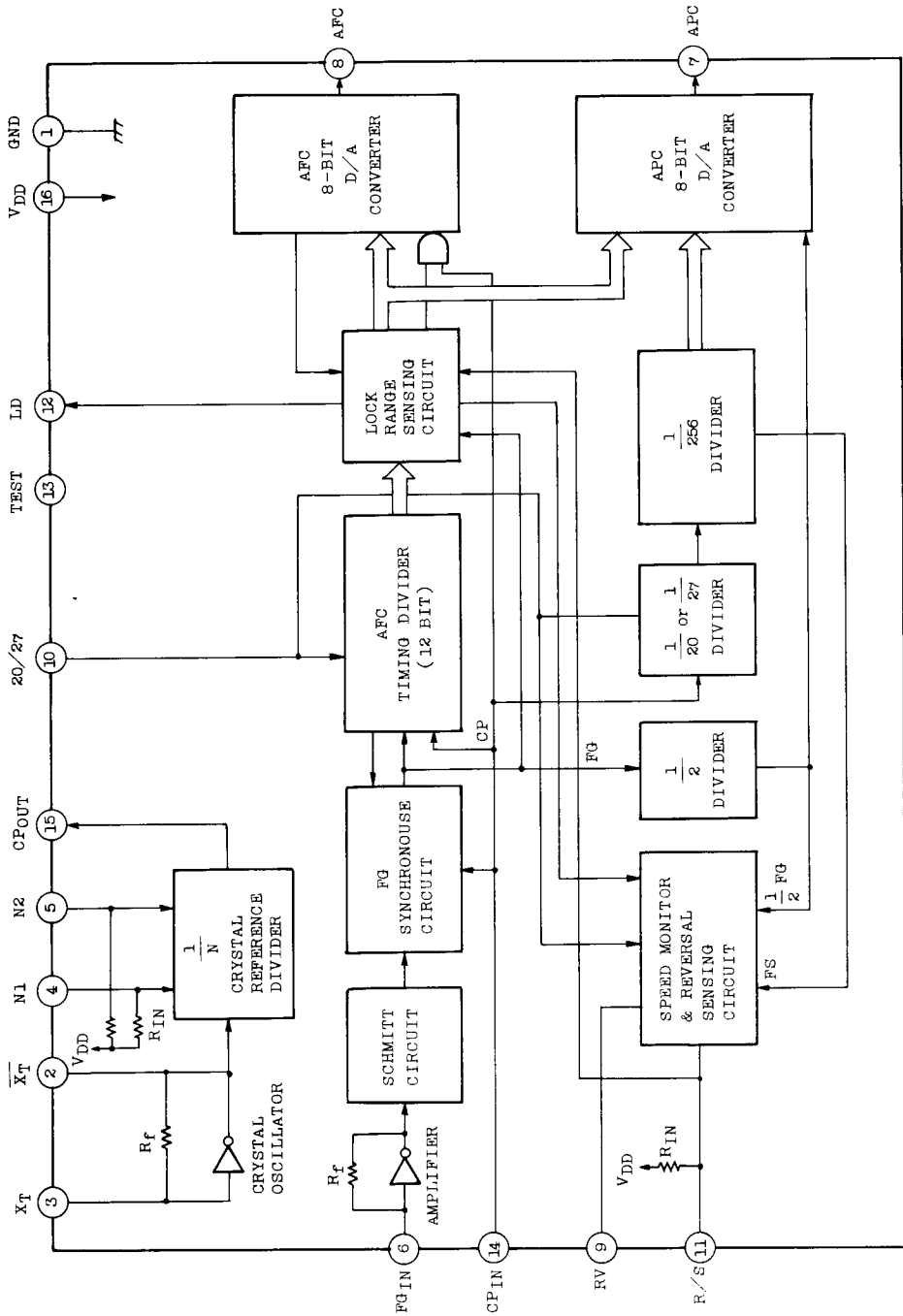

## ELECTRICAL CHARACTERISTICS (Unless otherwise specified, $V_{DD}=5V$ , $T_a=25^{\circ}C$ )

CHARACTERISTIC		SYMBOL	TEST CIRCUIT	TEST CONDITION	MIN.	TYP.	MAX.	UNIT		
Operating Supply Voltage		$V_{DD}$	-	*	4.5	5.0	5.5	V		
Operating Supply Current		$I_{DD}$	1	$X'tal=8MHz$ $CPIN=CP_{OUT}$	*	-	5.0	12.0	mA	
Operating Frequency Range	XT	$f_{XT}$	2	*	1.0	~	8.0	MHz		
	CPIN	$f_{CP}$	3	Square wave	*	0.05	~		4.0	
	FGIN	$f_{FG}$	-	$V_{IN}=0.5V_{p-p}$ Sin wave	*	-	~	10	kHz	
Input Operating Voltage		FGIN	$V_{IN}$ FG	4	$f_{FG}=10kHz$ Sine wave	*	0.5	~	$V_{DD}-0.5$	Vp-p
AFC, APC D/A Converter	Ladder Resistor		$R_L$	6			30	50	75	k $\Omega$
	Max. Deviation			-	$V_{DD}=4.5\sim 5.5V$		-	$\pm 2.5$	$\pm 6.5$	LSB
	Resolution			-			-	$V_{DD}/256$	-	V
	Temperature Drift			-			-	$\pm 1$	-	LSB
Pullup Resistor		$R_{IN}$	-	N1,N2,20/27,R/S	*	10	30	50	k $\Omega$	
Input Voltage	"H" Level	$V_{IH}$	-	N1,N2,20/27,R/S	*	$V_{DD}\times 0.8$	~	$V_{DD}$	V	
	"L" Level	$V_{IL}$	-	CPIN	*	0	~	$V_{DD}\times 0.2$		
Input Leak Current		$I_{IH}/I_{IL}$	-	CPIN	*	-	-	$\pm 1.0$	$\mu A$	
Output Current	"H" Level	$I_{OH}$	-	RV, LD		$V_{OH}=4V$	-0.5	-1.0	-	mA
	"L" Level	$I_{OL}$	-	CPOUT		$V_{OL}=1V$	0.5	1.0	-	
Amplifier Feedback Resistor	XT	$R_f$	5			100	200	500	k $\Omega$	
	FGIN				300	500	800			

\* : Guaranteed within the range of  $V_{DD}=4.5V\sim 5.5V$ ,  $T_a=-40\sim 85^{\circ}C$ .

# TC9203P/F

## FUNCTIONAL EXPLANATION OF EACH TERMINAL

PIN No.	SYMBOL	TERMINAL NAME	FUNCTIONAL & OPERATION EXPLANATION	REMARKS
16	V <sub>DD</sub>		Power supply voltage terminal and grunding terminal.	
1	GND			
2	$\overline{X_T}$	Crystal Oscillation Terminal	Crystal oscillator is connected.	with a built-in feedback resistor.
3	X <sub>T</sub>			
4	N <sub>1</sub>	Reference Divided Frequency Switching Terminal	Switching of divided frequency from the crystal reference frequency divider into 1/5, 1/6 and 1/12 is possible.	with a built-in pull-up resistor.
5	N <sub>2</sub>			
6	FG <sub>IN</sub>	FG Pulse Input Terminal	Frequency generator input.	with a built-in amplifier.
7	APC	APC Output Terminal	8 bit DAC output terminal for phase-voltage conversion.	
8	AFC	AFC Output Terminal	8 bit DAC output terminal for frequency-voltage conversion.	
9	RV	Reverse Signal Output Terminal	Terminal for motor reverse signal Output.	
10	20/27	Lock Range Switching Terminal	Terminal for switching lock range. H or NC=1/20, L=1/27.	with a built-in pull-up resistor
11	R/S	RUN/STOP Input Terminal	Motor RUN/STOP signal input terminal. H or NC=STOP, L=RUN.	with a built-in pull-up resistor
12	LD	Lock Detecting Terminal	This terminal becomes H when the motor speed is within the lock range and otherwise L.	
14	CP <sub>IN</sub>	Reference Frequency Input Terminal	Normally connected to CPO <sub>UT</sub> . For external fine adjustment input from an external oscillator.	
15	CPO <sub>UT</sub>	Reference Frequency Output Terminal	Terminal for divided output from the crystal reference frequency divider. Normally connected CP <sub>IN</sub> .	
13	TEST	Test Terminal	Input terminal of internal test. Generally ground.	

OPERATION

1. Crystal oscillation terminals ( $X_T$ ,  $\overline{X_T}$ )

- . The crystal oscillator is used by connecting as shown below.

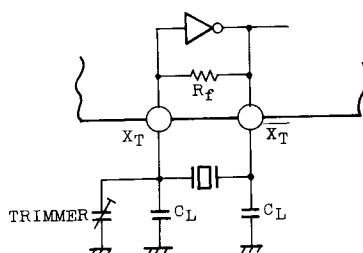

.  $C_L$  of 10~30pF is appropriate.

Crystal oscillation frequency is calculated by the following equation according to number of FG pulses of a motor to be used.

$$f_X = \frac{R}{60} \times FG' \times 128 \times (20 \text{ or } 27) \times N \quad (\text{Hz})$$

(Note) (20 or 27) : 20 at 20/27="H" or Open.  
 27 at 20/27="L".

$f_X$ : Crystal oscillation frequency,  $FG'$ : number of FG pulse generated per revolution of motor,  $R$ : revolution of motor per minute,

$N$  : Ratio of frequency division of the crystal reference frequency divider.

(Refer to Item 9.)

- . Maximum operating frequency is above 8MHz and crystals up to 8MHz can be used.

2. Reference frequency input/output terminals ( $CP_{IN}$ ,  $CP_{OUT}$ )

- . Divided output  $\frac{f_X}{N}$  from the crystal reference frequency divider is available at  $CP_{OUT}$ , which is normally connected  $CP_{IN}$ .
- . When an external oscillator (CR oscillator, etc.) is connected to  $CP_{IN}$ , motor speed can be finally adjusted.

### 3. FG pulse input terminal (FG<sub>IN</sub>)

- . This is the input terminal of FG pulse that shows the motor speed. This FG pulse becomes comparison frequency.
- . This terminal has built-in Amplifier and Schmitt circuit. FG pulses are applied through capacitor coupling and small amplitude is enough for proper operation.

### 4. Lock range switching terminal (20/27)

- . This terminal is for switching lock range of motor, with a pull-up resistor and chattering preventive circuit.

(TRUTH TABLE)

20/27	DIVIDED FREQUENCY	LOCK RANGE
L	1/27	+3.4~-3.9% of reference cycle
H or NC	1/20	+4.6~-5.3% of reference cycle

### 5. APC, AFC output terminal (APC, AFC)

- . AFC (speed control output) is a F-V converter for FG frequency, and is consisting of a 8 bit D/A converter.
- . APC (phase control output) is a phase comparator ( $\phi$ -V converter) that compares phase difference  $\phi$  between 1/2 FG and reference frequency FS', and is also consisting of a 8 bit D/A converter.
- . Both APC and AFC perform the following 3 operations according to FG<sub>IN</sub> frequency.
  - a. When FG<sub>IN</sub> frequency is within the lock range:
    - Both APC and AFC perform the normal operation for FG<sub>IN</sub>.
  - b. When FG<sub>IN</sub> frequency is below the lock range (under speed):
    - APC and AFC outputs are both fixed at "H" level.
  - c. When FG<sub>IN</sub> frequency is above the lock range (over speed):
    - APC and AFC outputs are both fixed at "L" level.
- . When a motor is in STOP state (P/S=H or NC), both AFC and APC are fixed "L" level.

AFC Output change status for FGIN frequency

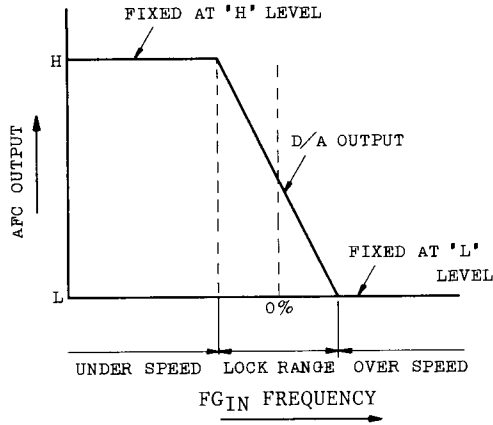

APC Output change status for phase difference  $\phi$ .

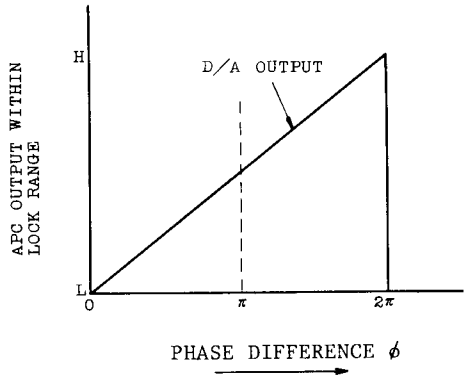

. AFC and APC timing chart within lock range.

a. AFC (SPEED CONTROL SYSTEM)

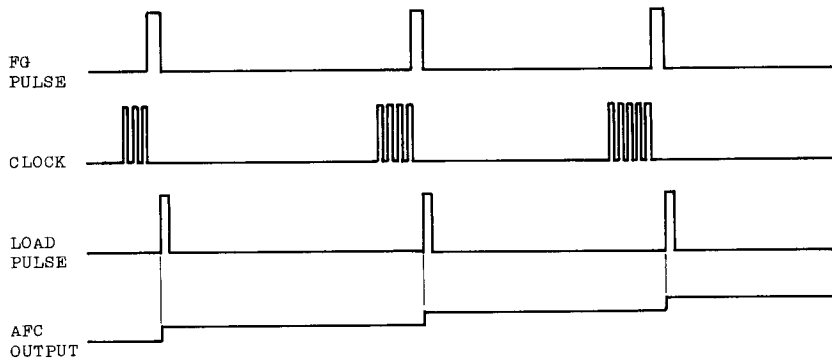

b. APC (PHASE CONTROL SYSTEM)

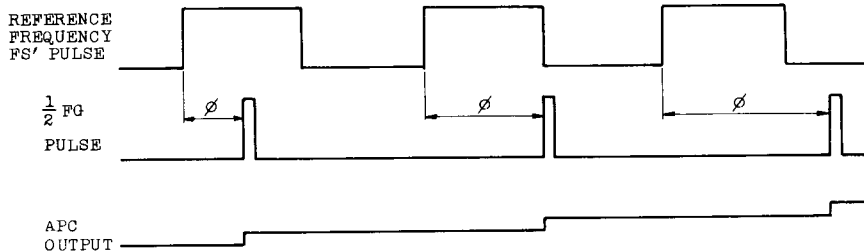

# TC9203P/F

## 6. Lock detecting terminal (LD)

- . This terminal is the lock detecting output and is placed at "H" level when FG<sub>IN</sub> frequency is within the lock range and otherwise, placed at "L" level.

## 7. RUN/STOP input terminal (R/S)

- . RUN/STOP signals of the motor are input to this terminal.
- . This terminal has a pull-up resistor and a chattering preventive circuit.
- . During RUN (R/S=L), AFC, APC and LD perform the above-mentioned operations for FG<sub>IN</sub> frequency, and during STOP (R/S=H or NC), AFC, APC and LD are all fixed at "L" level.

## 8. Reverse signal output terminal (RV)

- . At the switching of lock range from 1/20 to 1/27 or the operating from RUN to STOP, reverse signal for braking the motor is output through this terminal.
- . Change of RV output status

PREVIOUS STATUS	RV OUTPUT CHANGE TO "H" LEVEL	RV OUTPUT CHANGE TO "L" LEVEL
During normal rotation (during lock) at 1/20.	When the lock range is switched from 1/20 to 1/27.	When the motor speed is locked at 1/27, or when FG <sub>IN</sub> 1/8FS, or when the lock range is switched from 1/27 to 1/20.
During normal rotation (during lock) at 1/20 or 1/27.	When the operation is switched from RUN to STOP.	When FG <sub>IN</sub> 1/8FS or when the operation is switched from STOP to RUN.

- . In other cases than above, RV output is not changed and fixed at "L" level.
- . Further, if FG frequency rises up to 1.5 times of normal rotation at 1/20 (2 times of normal rotation at 1/27), RV output is reset

## 9. Reference divided frequency switching terminal (N1, N2)

- . Divided frequency 1/N of the crystal reference frequency divider can be switched to 1/5, 1/6 or 1/12 by number of FG pulses or a crystal used.



. This terminal has a built-in pull-up resistor.

(TRUTH TABLE)

N1	N2	1/N
H	H	1/5
L	H	1/6
H	L	1/12

1/N: CRISTAL REFERENCE DIVIDED FREQUENCY

(Note) Don't use mode, N1=N2="L", because this mode is test mode.

CAUTION IN APPLICATION

. APC and AFC terminals are for the 8-bit D/A converter outputs, which are directly output from the R-2R ladder type resistor network as shown in the following diagram. Impedance of these outputs becomes equal to the ladder resistor value  $R_L$ . Therefore, input impedance at the receiving side of these terminals shall be designed accordingly.

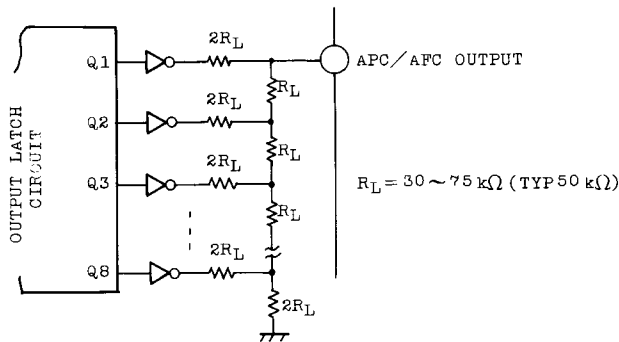

. A filter for an externally mounted differential amplifier on an application circuit shall be selected to meet the response characteristic of a motor to be used.

# TC9203P/F

## CHARACTERISTIC TEST CIRCUIT

(1) Operating supply current  $I_{DD}$

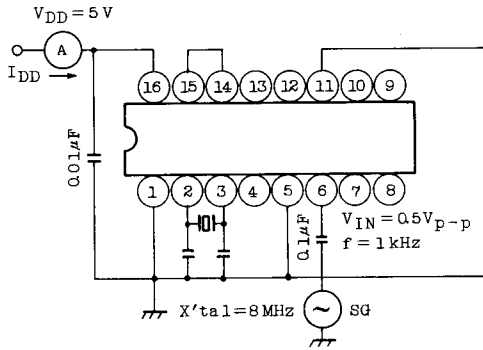

(2) XT Operating frequency range  $f_{MAX}(f_{XT})$

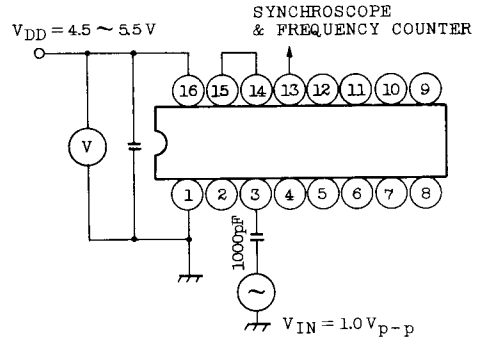

(3) CP<sub>IN</sub> Operating frequency range  $f_{MAX}(f_{CP})$  (4) FG<sub>IN</sub> Input sensitivity  $V_{INFG}$

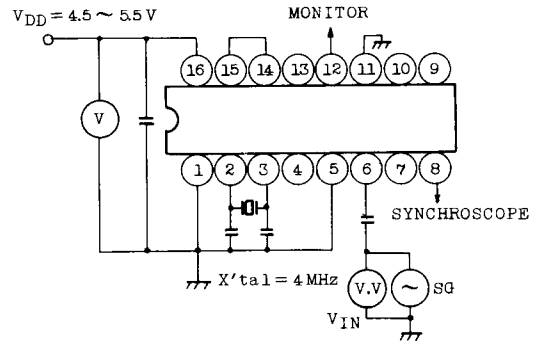
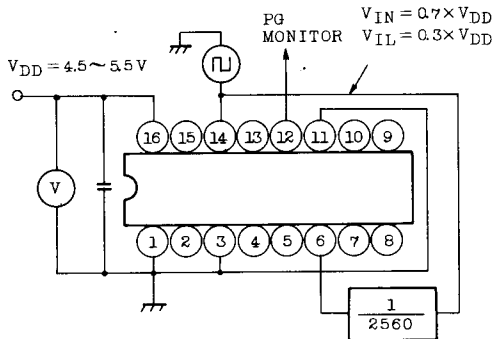

(5) Amplifier feedback resistor

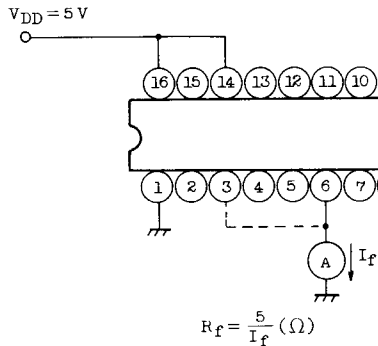

(6) D/A Converter ladder resistor  $\bar{R}_L$

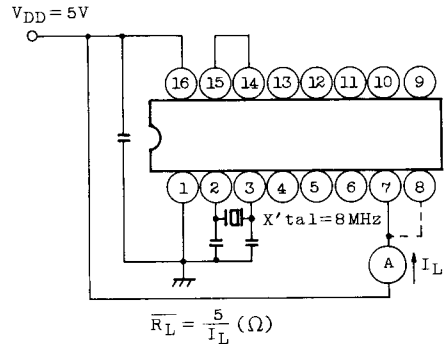

CHARACTERISTIC DATA

$f_{MAX}(X_T) - V_{DD}$

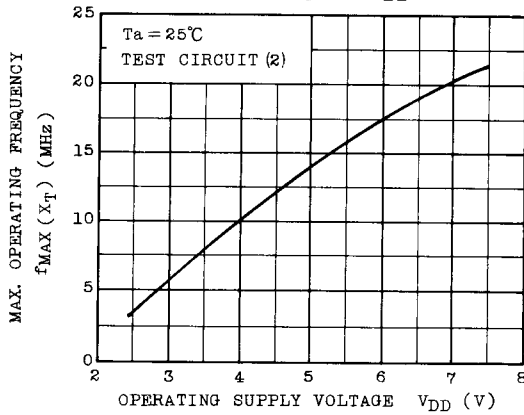

$f_{MAX}(X_T) - T_a$

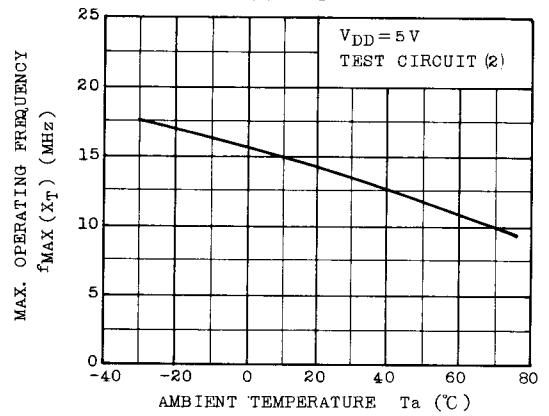

$f_{MAX}(CPIN) - V_{DD}$

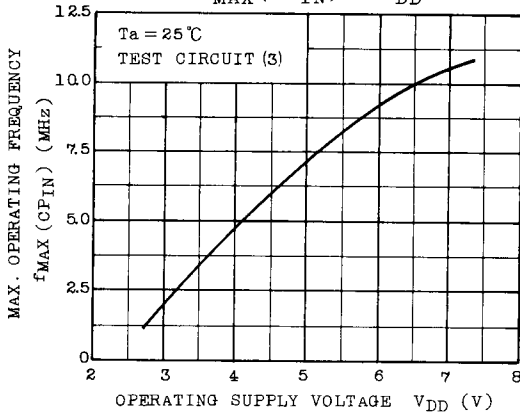

$f_{MAX}(CPIN) - T_a$

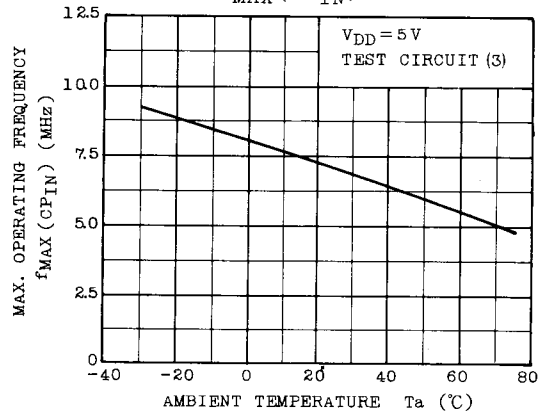

$I_{DD} - V_{DD}$

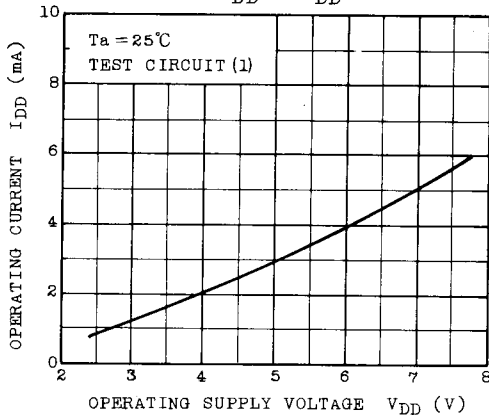

$V_{IN}(FG_{IN}) - V_{DD}$

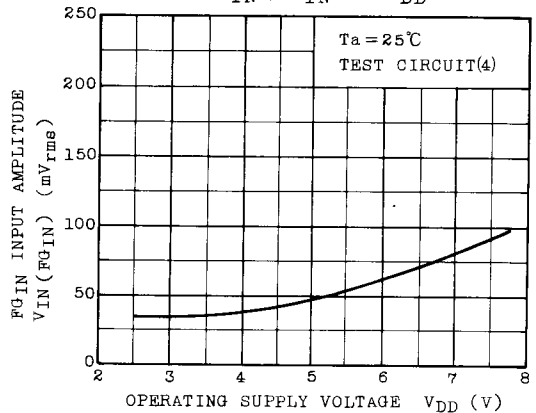

# TC9203P/F

## EXAMPLE APPLICATION CIRCUIT

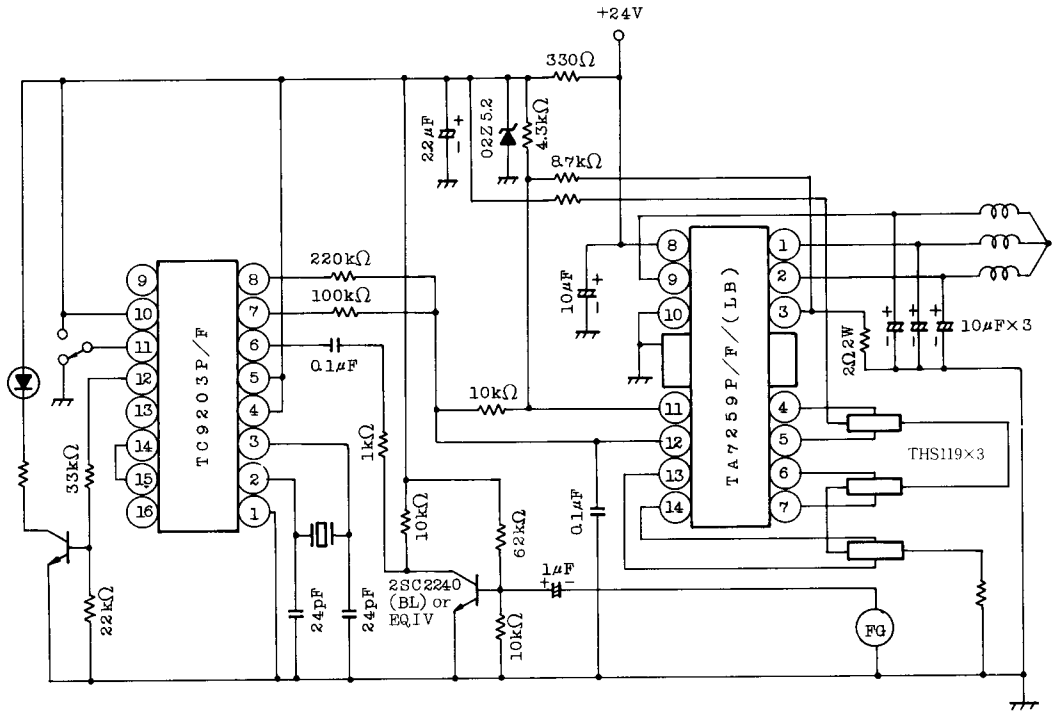

Example of crystal oscillation frequency calculation.

When FG' (number of FG pulse) = 180 pulses and R (revolution of motor) = 200r.p.m., if the dividing frequency of reference divider and lock range is set at N=5 dividing frequency and 20/27=20, the crystal oscillation frequency  $f_X$  is as follows:

$$f_X = \frac{R}{60} \times FG' \times 128 \times 20 \times N = \frac{200}{60} \times 180 \times 128 \times 20 \times 5 = 7,680\text{MHz}$$