

# Kit 1. THREE DIGIT COUNTER

This is a low cost basic 3-digit counter unit which can provide the basis for many applications where a counter is required. Connections are provided to connect together two or more counters to make a six or nine digit unit. The display is a single unit LED multiplexed display.

The kit is constructed on a single-sided printed circuit board (PCB). Protel Autotrax & Schematic were used to design the boards.

## ASSEMBLY

It is generally best to add the components with the lowest height first (like resistors and jumper connections) for ease of soldering. There are 8 jumper wire connections to put in. Use the wire cut from the leads of the passive components for this. Use the 6 wire harness & header connector to connect to the counter module described below. On the 3 digit display the decimal points show the correct orientation.

The LED counter part of the PCB has been constructed so that it may be cut off and located away from the main circuit board.

## CIRCUIT DESCRIPTION

In general three or four digit counters can be made a number of ways. You can use a single 74C92x 4 digit counter chip or a number of 4029 cmos single digit counters. Problems with the former are cost, while the latter require too many IC's and thus take up too much PCB space. The circuit used here is a compromise between these two approaches.

Over the last few years a single micro-processor chip like the Atmel AT90S1200 can do away with all cmos IC's. See our Kits 129, 141, 148 and 154 for such examples.

The circuit described in this kit uses two IC's. The 14553 is a 3-digit BCD (binary coded decimal) counter. Inside the chip, each counter drives a 4-bit latch which quad 3-input multiplexer. The chip has Carry, Reset, an input clock and Latch Enable. The 1nF mylar capacitor on pins 3 and 4 sets the multiplex scan rate to about 1 kHz.

The four outputs (Q0 to Q3) are fed into the 14511 cmos 7-segment decoder driver. The outputs of this driver then go to the 3-digit multiplexed display unit. Each digit is turned on at the correct time via the display control outputs at pins 2, 1 and 25 of the 14553. They are active low outputs. Each drives a BC557 pnp transistor via a 4k7 resistor. The transistors in turn switch the common cathod of the digits in the display.

Log onto <http://www.onsemi.com/> to get the data sheets for the 14511, 14553 and 14093 used in this Kit.

## COUNTER MODULE FOR 3-DIGIT COUNTER

This counter module shows how to use the 3 digit counter for low frequency counting Connect the 6 wire harness to the bottom right of the main board. Make sure to get the wires around the correct way. Solder the 6 pin header to

the counter module. The module has a COUNT and RESET push switch.

Two or three Kit 1's may be connected together to make 6 or 9 digit counter modules. Extra 6 wire header/harness sets will have to be purchased to do this. Or you can just use hookup wire directly. Connect from the bottom left 6 pin header to the bottom right of the next module.

## CIRCUIT DESCRIPTION

The counter module is a typical debounce circuit. The resistance and capacitor provide a delay period during which the noise of the switch connection will not register a 'count'. The hatkey switch used are very noisy switches but this debounce circuit take care of the problem for as fast as manual pressing will allow. Digital inputs from other sources may be routed through the board but the debounce circuit will have to be changed if the input frequency is higher than 100 to 150 Hz (cycles / second.)

## WHAT TO DO IF IT DOES NOT WORK

Poor soldering is the most likely reason that the circuit does not work. Check all solder joints carefully under a good light. Next check that all components are in their correct position on the PCB. Do the keyswitches have their flat at the bottom as indicated on the PCB overlay? Is the 14093 in the correct way with pin 1 facing the 6 pin connector? Is the 6 pin connector in the correct way. Thirdly, follow the track with a voltmeter to check the potential differences at various parts of the circuit.

## COMPONENTS

### Main Circuit Board

Resistors (0.25W, 5%)	
1M black brown green	2
100K black brown yellow	1
4K7 yellow violet red	3
330R orange orange brown	7
IC 14553	1
IC 14511	1
16 pin IC sockets	2
BC557B	3
9V battery snap	1
1n capacitor mylar	1
1N4148	1
6 wire cable harness and connector	1 set
3 Digit LED display	1
Kit 1 PCB	1

### Counter Circuit

Resistors (0.25W, 5%)	
470K yellow violet yellow	2
10nF mylar capacitors	2
Hatkey switches	2
IC 14093	1
14 pin IC sockets	1
Counter PCB	1

Log onto <http://www.kitsrus.com/> to see our other kits.

# Kit 1. THREE DIGIT COUNTER

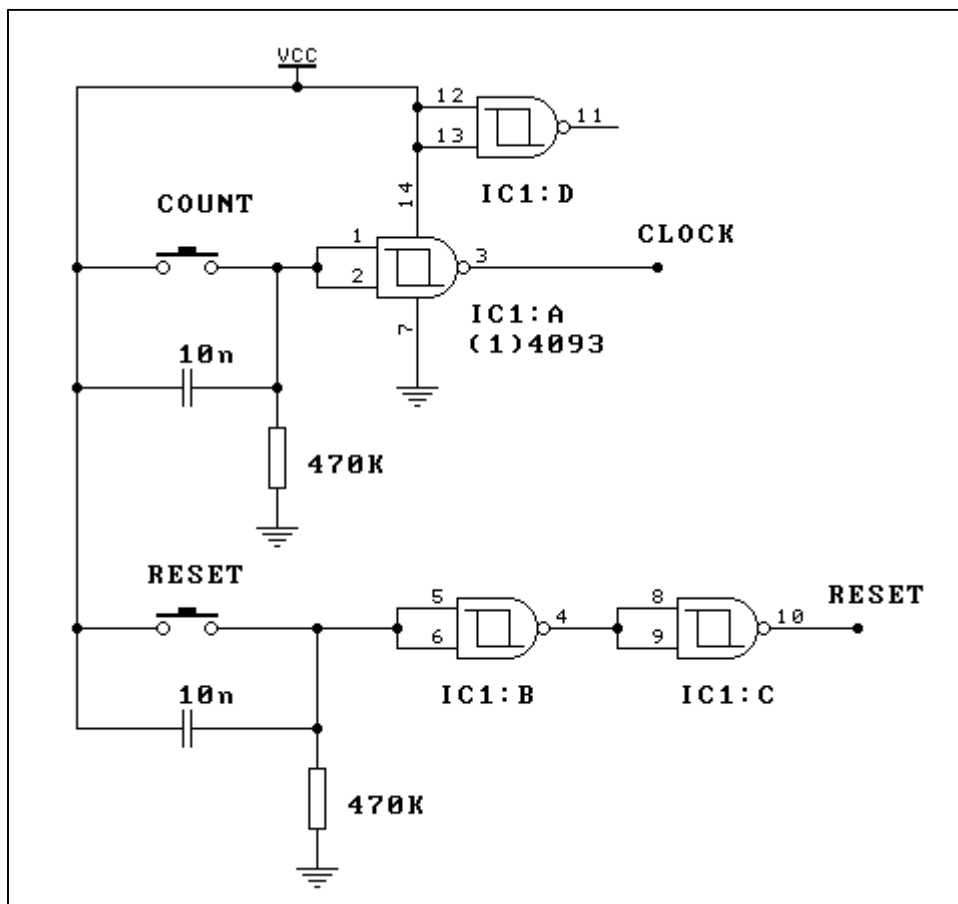
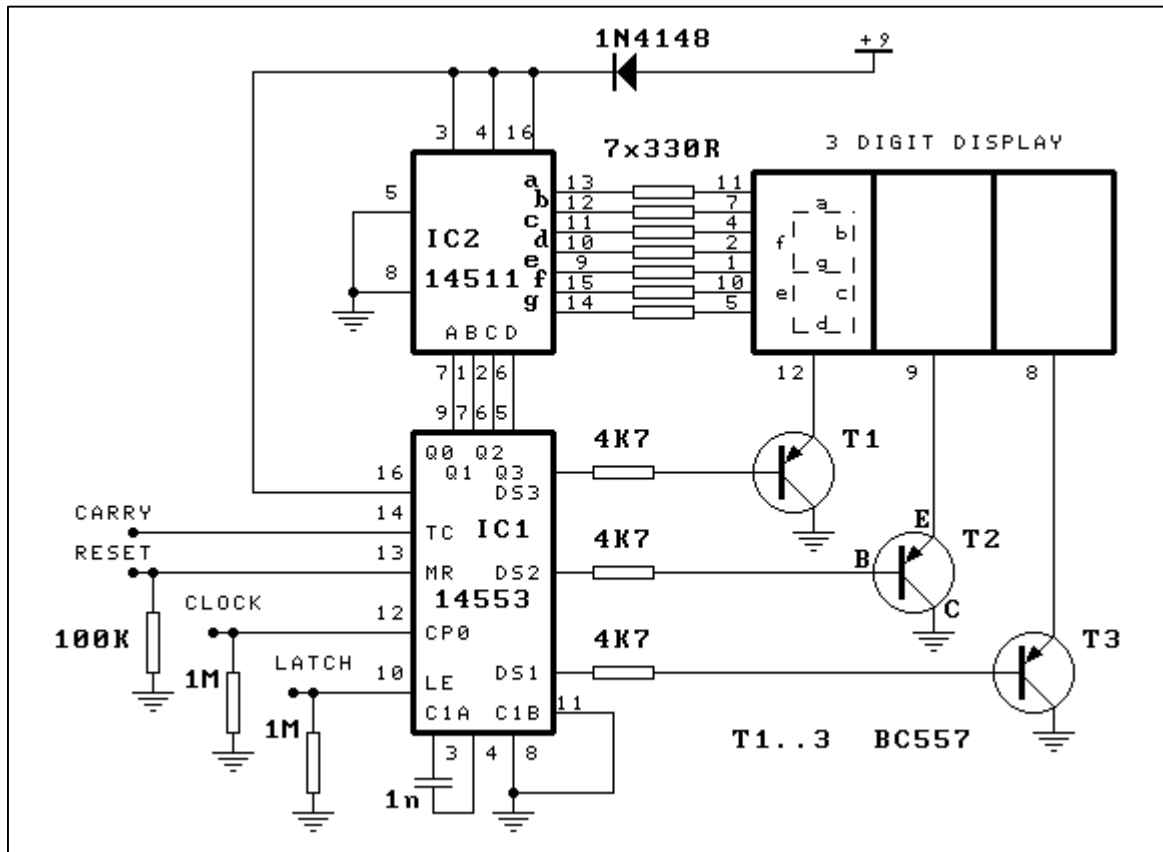

Debounced Count Module