

36842-BT

Charge/Discharge Protection Board for 12V LiPo Batteries

Module for controlling the charge & discharge of 3 series connected LiPo cells with a nominal voltage of 3.6V/3.7V ea. (18650, 26650 etc).

Charging Voltage: 12.6V-13.0V

Continuous Discharge Current: 20Amax

Continuous Charge Current: 10Amax

Maximum Charging/Discharging Power: 252W

Quiescent Current: ~ 25uA

Over Charge Protection: ~ 4.25V/cell

Auto Recovery: ~4.15V

Over Discharge Protection: ~2.5V/cell

Auto Recovery: ~3.2V

L: 2-5/16" W: 13/16" H: 1/4" WT: .1

TYPICAL APPLICATION
Cells, Tabs, Spacers **NOT**
Included



NOTES:

Always start with fresh batteries from same Mfg. and rating.

Never Short Circuit

CONNECTIONS

DO NOT MISWIRE!!

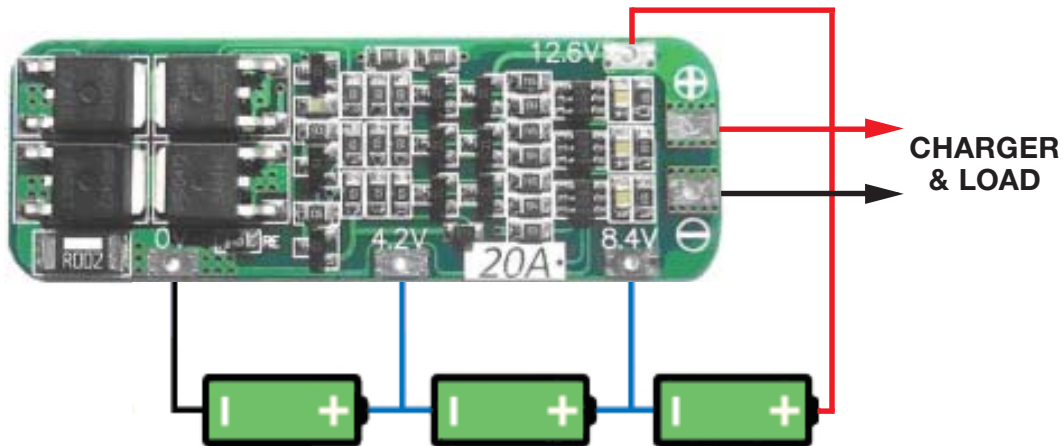

Information including Drawings, Schematics, Links and Code (Software) Supplied or Referenced in this Document is supplied by MPJA inc. as a service to our customers and accuracy or usefulness is not guaranteed nor is it an Endorsement of any particular part, supplier or manufacturer. Use of information and suitability for any application is at users own discretion and user assumes all risk.

Information Subject to Change Without Notice
All rights are retained by the respective Owners/Author(s)



MARLIN P. JONES & ASSOC., INC.

P.O. Box 530400 Lake Park, FL 33403

800-652-6733 FAX 561-844-8764

WWW.MPJA.COM