

33997-MI

300mm Linear Guide Rail with Stepmotor

MOTOR SPECIFICATIONS

Part #	Step Angle (Deg.)	Motor Length (mm)	Rated Current (A)	Resistance (Ohms)	Inductance (mH)	Hold Torque (kg-cm)	Rotor Inertia (g-cm ²)	Lead Wires
ST57H5605	1.8	56	1.2	3.5	11	12	280	4

MECHANICAL

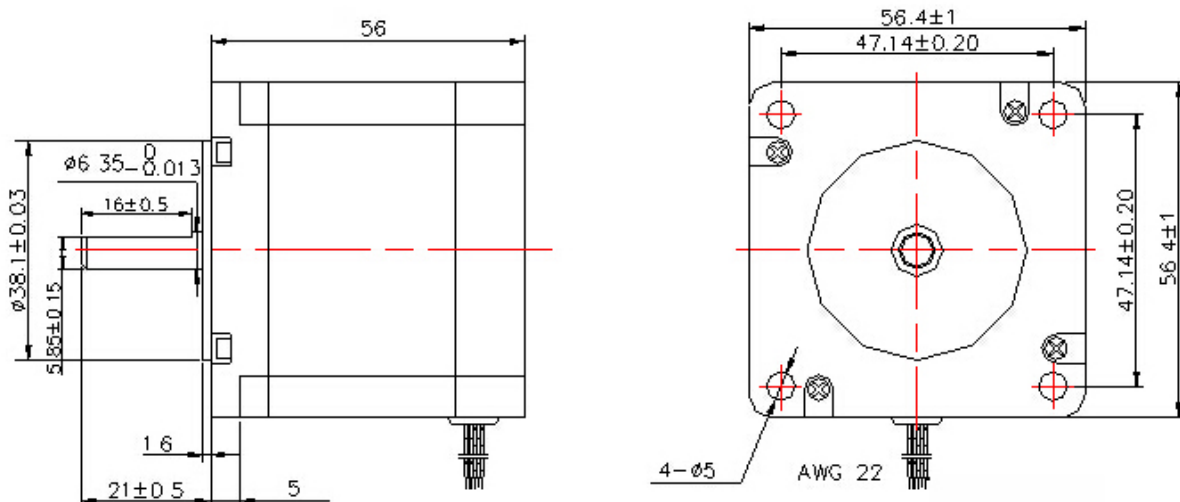

WIRING

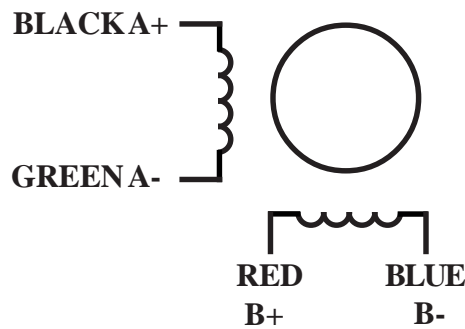

Information obtained from or supplied by Mpja.com or Marlin P. Jones and Associates inc. is supplied as a service to our customers and accuracy is not guaranteed nor is it definitive of any particular part or manufacturer. Use of information and suitability for any application is at users own discretion and user assumes all risk.



MARLIN P. JONES & ASSOC., INC.

P.O. Box 530400 Lake Park, FL 33403
 800-652-6733 FAX 561-844-8764
 WWW.MPJA.COM