

32350-MI

Mini Dimmer/Heater Control

Improved 2KW Mini dimmer control board using the BTA 24-800B TRIAC

Volts: 50-220VAC 50/60Hz

Max Current: 8A

Does not contain any RFI/EMI filtering

L: 2" O/A W: 2-1/4" O/A H: 1-1/4" WT: .1

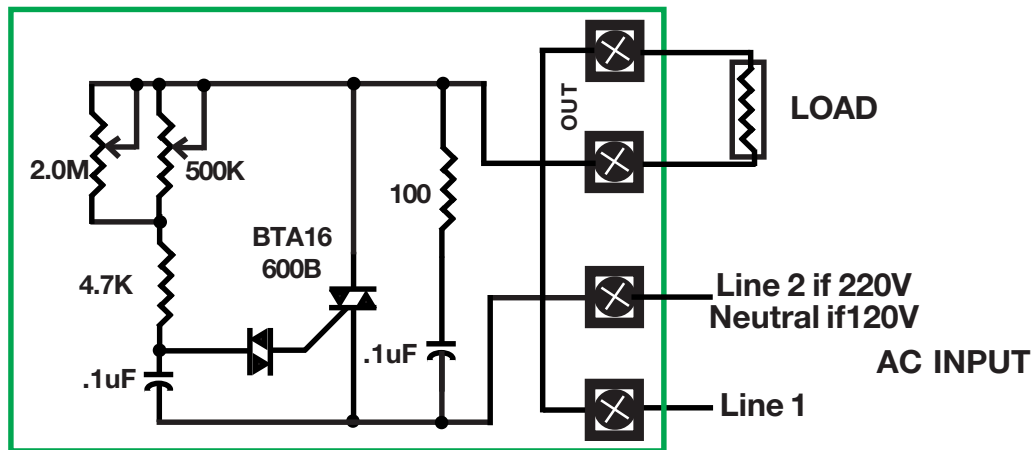
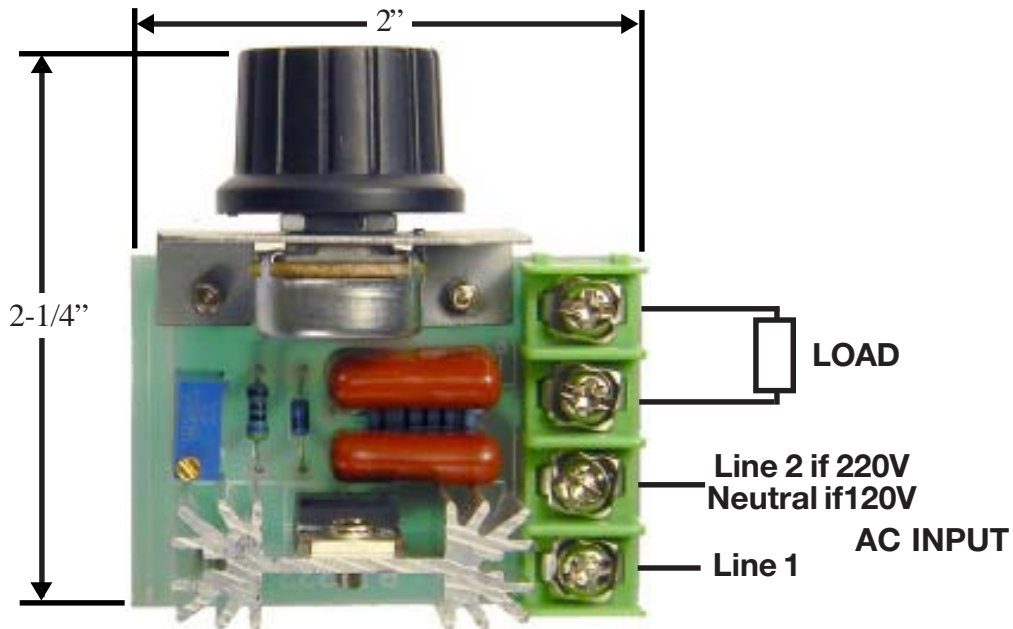

Information obtained from or supplied by Mpja.com or Marlin P. Jones and Associates inc. is supplied as a service to our customers and accuracy is not guaranteed nor is it definitive of any particular part or manufacturer. Use of information and suitability for any application is at users own discretion and user assumes all risk.



MARLIN P. JONES & ASSOC., INC.

P.O. Box 530400 Lake Park, FL 33403
800-652-6733 FAX 561-844-8764
WWW.MPJA.COM