

# VLT130 Series

# 18090-PS

## Single, Triple and Quad Output 130W Universal Input AC/DC Power Supplies

Unless stated otherwise, specifications are typical and rated at full load, nominal input voltage, convection cooling and 25°C.

### INPUT

AC Input	Auto-ranging	90 to 132V 180 to 264V
Efficiency		82%
Input Frequency		47— 63 Hz
Input Current	Full Load at Low Line	3.3Arms, max
Inrush Current	High Line	40A, max

### OUTPUT

Output Power <sup>4,5</sup>	All Outputs No Fan All Outputs With Fan	80W max 130W max
DC Output		See table
Hold-Up Time	115V/230V	15ms
Set Point Accuracy	V1 and V2 V3 and V4	+1% +5%
Line Regulation	Low Line to High Line	0.3%
Load Regulation	Min to Full Load V1 and V2 V3 and V4	+1% +5%
Transient Response	50% to Full Load Voltage Deviation Recovery Time	<7% <1ms
OVP	3.3V Output 5V Output	5.1V, +0.4V 6.2V, +0.4V
Overload Protection	Primary Limited	195W, +35W
Short Circuit Protection	Auto Recovery <6s	Short Term
Ripple and Noise	V1 and V2 V3 and V4	50mV 1%
Power Fail Signal <sup>2</sup>	TTL	2ms warning
Remote Sense <sup>3</sup>	Line Compensation on V1 and V2	450mV
Power Good <sup>2</sup>	Delay after V1 high	10ms
Output Rise Time		<10ms
Redundancy	see page 24	1+1
Paralleling Function		No

### ENVIRONMENTAL

Operating Temperature		0 to 50°C
Storage Temperature		-40 to 85°C
Cooling	Convection 15 CFM	80W 130W
Relative Humidity	Non condensing	95%, max
MTBF	MIL-HDBK-217F	>200,000 hrs



### EMC AND SAFETY

CE Mark	Full compliance with the LVD
EMC	EN55022-B, CISPR22-B, FCC Part 15 Class B, EN50082-1
Harmonic Correction	EN61000-3-2 Class A and D
Agency Approvals	VDE, UL, c-UL
Safety Standards	IEC950, EN60950, UL1950 Class 1 SELV
Safety File numbers	VDE: 18934-3336 UL: E150565

### MECHANICAL

AC Input Connector J1	Molex 3 position, 0.156 center header 26-60-4030 or equivalent
Ground Connector	Spade connector
Output Connector J2	Molex terminal block or equivalent
Output Connector J3	Molex 22-23-2081 or equivalent
Size	3x5x1.07 (76.2x126.9x27.2mm)
Weight	12oz (340g)

#### INPUT CONNECTOR J1

Pin 1	Neutral
Pin 2	Line
<b>Input Spade Connector</b>	
GND	Ground

#### OUTPUT CONNECTOR J2

	Single Output	Quad Output
Pin 1	No Connection	V3
Pin 2	V1B	V2
Pin 3	DC Return	DC Return
Pin 4	DC Return	DC Return
Pin 5	V1A	V1
Pin 6	No Connection	V4

#### OUTPUT CONNECTOR J3

	Single Output	Quad Output
Pin 1*	V1 Current Share	V2 Current Share
Pin 2*	V1 Current Share	V1 Current Share
Pin 3	No Connection	Power Fail
Pin 4	Common	Common
Pin 5	-V1A Sense	-V1 Sense
Pin 6	+V1A Sense	+V1 Sense
Pin 7	+V1B Sense	+V2 Sense
Pin 8	-V1B Sense	-V2 Sense

\* Pins 1 and 2 are not connected for models with no current share

# VLT130 Series

Model without Current Share	Model with Current Share	Output	Nominal Output Voltage	Voltage Set Point	Max Current <sup>1</sup> No Fan	Max Current <sup>1</sup> 180 LFM	Min. Load
VLT130-1006 <sup>5</sup>	VLT130-1106 <sup>5</sup>	V1	3.3V	3.3V	20.0A	32.0A	0.5A
VLT130-1000 <sup>5</sup>	VLT130-1100 <sup>5</sup>	V1	5V	5.1V	16.0A	25.5A	0.5A
VLT130-1001 <sup>5</sup>	VLT130-1101 <sup>5</sup>	V1	12V	12.0V	6.7A	10.8A	0.5A
VLT130-1002 <sup>5</sup>	VLT130-1102 <sup>5</sup>	V1	15V	15.0V	5.4A	8.7A	0.5A
VLT130-1003 <sup>5</sup>	VLT130-1103 <sup>5</sup>	V1	24V	24.0V	3.4A	5.4A	0.5A
VLT130-1004 <sup>5</sup>	VLT130-1104 <sup>5</sup>	V1	48V	48.0V	1.7A	2.7A	0.5A
VLT130-3110 <sup>4</sup>	VLT130-3100 <sup>4</sup>	V1	5.1V	5.1V	10.0A	14.0A	0.5A
		V2	3.3V	3.3V	10.0A	16.0A	0.5A
		V3	12V	12.7V	1.0A	1.5A	0.1A

<sup>5</sup>Maximum current per output channel. Do not exceed total output power rating

1. Maximum current per output . Do not exceed maximum output power rating.
2. Power Good and Power Fail signal on quad output models only.
3. The use of the Remote Sense function requires 15CFM / 180 LFM airflow.

4. Quad Output Models: The output section of the VLT130-4xxx is split into 2 independently regulated channels. Channel A consists of the main output V1 and auxilliary output V4. Channel B consists of the main output V2 and auxilliary output V3. The maximum output power that may be drawn per channel is 45W with convection cooling or 65W with fan cooling.

5. Single Output Models: The output section of the VLT130-1xxx is split into 2 independently regulated channels. Channel A consists of the main output V1A. Channel B consists of the main output V1B. An internal shunt resistor of value 0 ohms connects both channels of the power supply. In an event whereby this shunt resistor is removed, the maximum output power that may be drawn per channel is 45W with convection cooling or 65W with fan cooling.

VLT130 Single Output Connection Diagram

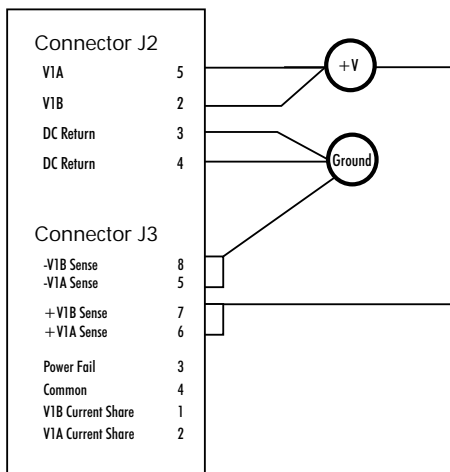

1. To connect the current sense pins 5,6,7 and 8 on connector J3 to the load, it is recommended to use 0.22 gauge twisted pair wire.
2. For single output units, an internal 0 ohm resistor shunt is used to internally connect the current share pins V1A Current Share (J3-2) and V1B Current Share (J3-1). These pins require no connection for applications that do not require 1+1 redundancy.
3. Pins J3-4, Common, should be connected to ground for correct operation.
4. The Power Fail signal J3-3 is not available as standard on single output units.

VLT130 Triple/Quad Output Connection Diagram

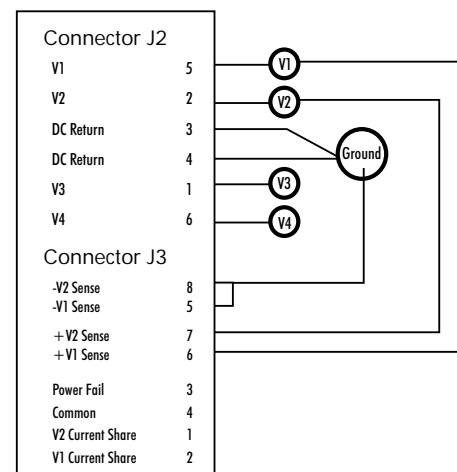

1. To connect the current sense pins 5,6,7, and 8 on connector J3 to the load, it is recommended to use 0.22 gauge twisted pair.
2. The Power Fail signal J3-3 is a TTL active high signal. The maximum source current is 0.45mA and the maximum sink current is 0.25mA.
3. Pin J3-4, Common, should be connected to ground for correct operation.
4. On models without the current share option, V1 and V2 Current Share Pins J3-1 and J3-2 are not connected.

# VLT130 Series

## VLT130 Single Output Connection Diagram in a 1+1 Redundant Configuration

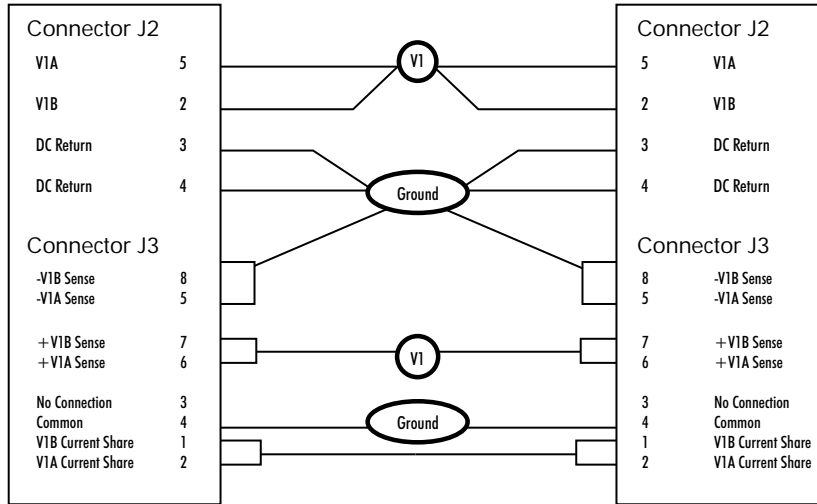

1. To connect the current sense pins 5,6,7 and 8 on connector J3 to the load, it is recommended to use 0.22 gauge twisted pair wire.
2. For single output units, an internal 0 ohm resistor shunt is used to internally connect the current share pins V1A Current Share (J3-2) and V1B Current Share (J3-1).
3. Pin J3-4, Common, should be connected to ground for correct operation.
4. The Power Fail signal J3-3 is not available as standard on single output units.

## VLT130 Quad Output Connection Diagram in a 1+1 Redundant Configuration

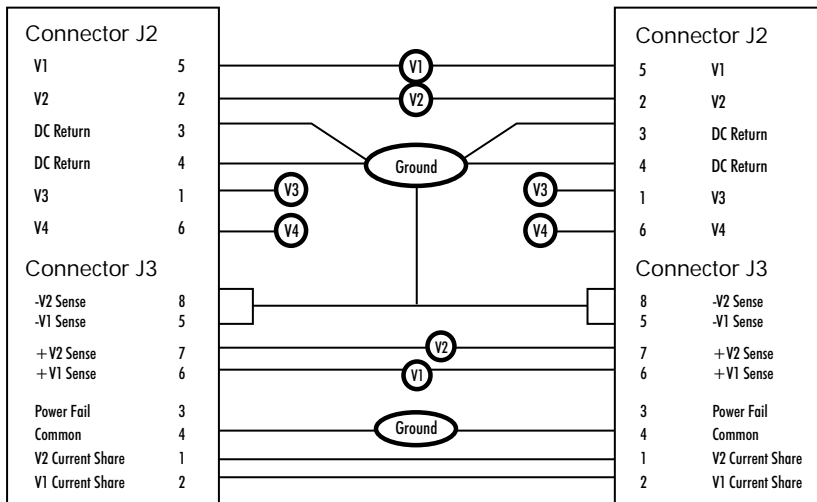

1. To connect the current sense pins, 5,6,7 and 8 on connector J3 to the load, it is recommended to use 0.22 gauge twisted pair wire.
2. The Power Fail signal J3-3 is a TTL active high signal. The maximum source current is 0.45mA and the maximum sink current is 0.25mA.
3. Pin J3-4, Common, should be connected to ground for correct operation.
4. Outputs V3 and V4 do not offer the current share feature.

# VLT130 Series

## Dimensions

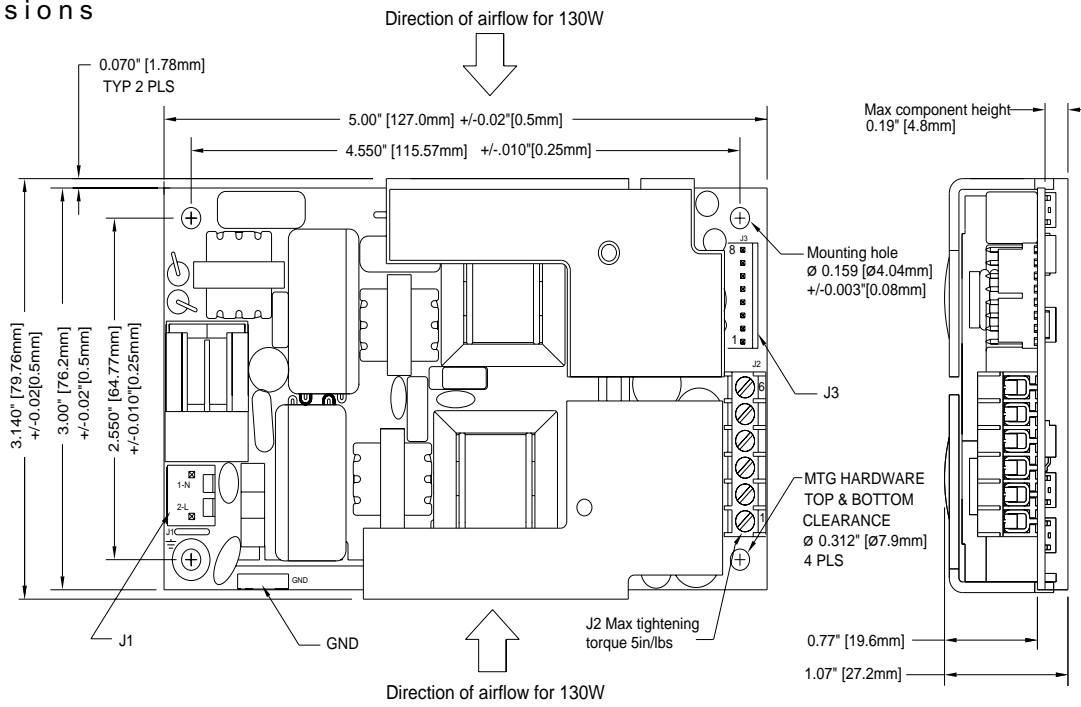

## Cover Kit p/n VLT80CK

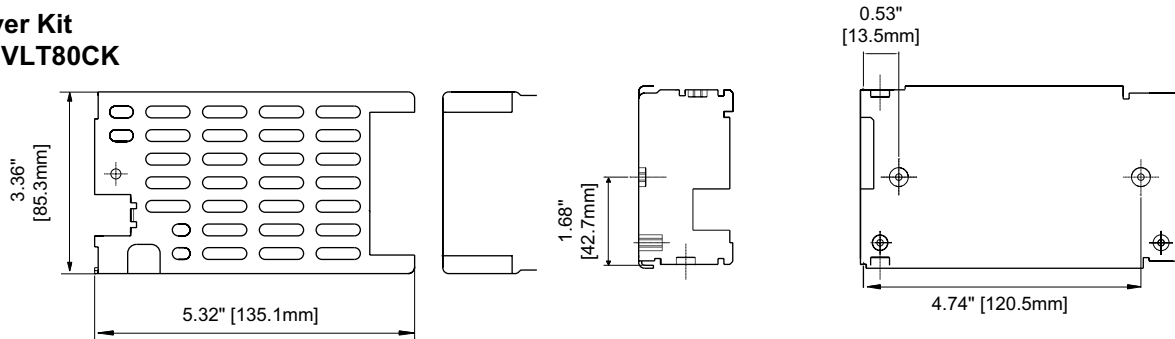

- Contents**
- Mounting bracket
  - Cover
  - Insulator
  - M3 fixing screws

## VLT80CK Derating Guidelines

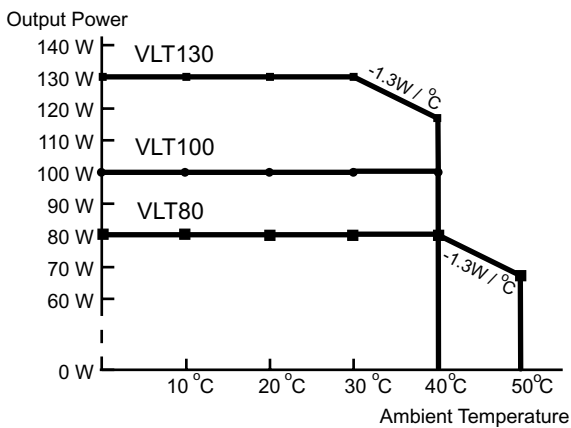

**VLT130:**  
Ambient >30 °C, derate by 1.3W/°C to 40 °C.  
For 130W output fan should be directed into the unit through the output connector opening.