



Time Switch

Instructions for models GE5191-SPDT, GE5191-DPDT

APPLICATION

The GE Time Switches (GE5191-SPDT, GE5191-DPDT and GE5191-SPDTG) are universal, electromechanical time switches which can be *field configured* for various power supply voltages. The voltage options include 120VAC, 208/240VAC and 277VAC – all within the same unit! Selection of the desired supply voltage is easily achieved by positioning “Jumpers” on the printed circuit board assembly (consult “Jumper Configuration” below). The mechanism is mounted in a NEMA indoor or outdoor enclosure and is intended for the control of lighting, heating, air conditioning, pumps, motors, or general electrical circuits in residential, commercial, industrial and agricultural facilities.

SPECIFICATIONS

Input Voltage: 120 VAC, 208/240 VAC, or 277 VAC in all units based upon “Jumper” configuration.

Switch Rating: SPDT or DPDT Models

Normally Open Contacts

- 30 A General Purpose, 120-277 VAC
- 12 A General Purpose, 277 VAC
- 20 A Resistive, 28 VAC
- 1 HP, 120 VAC, 2 HP, 240 VAC
- 1 HP, 277 VAC
- 20 A Ballast, 125 VAC, 10 A Ballast 277 VAC
- 8.3 A Tungsten, 120 VAC, 5.4A Tungsten, 277 VAC
- 125 VA Pilot Duty, 120 VAC
- 470 VA Pilot Duty, 240 VAC

Normally Closed Contacts

- 15 A General Purpose, 120-277 VAC
- 6 A General Purpose, 277 VAC
- 10 A Resistive, 28 VDC
- 1/4 HP, 120 VAC, 1/2 HP, 240 VAC
- 20 A Ballast, 125 VAC, 3 A Ballast 277 VAC
- 125 VA Pilot Duty, 120 VAC
- 275 VA Pilot Duty, 240 VAC

Note: If loads are connected to both NC and NO contacts, both contacts are derated to 67% of the above values.

ENVIRONMENTAL RATINGS

Ambient Temperature: -40°F to 130°F
Humidity: 0-95% RH, Non-condensing

WIRING CONNECTIONS

Screw clamp terminals for up to two #10 AWG wires per position.



INSTALLATION

CAUTION: Before wiring or service, power to this time switch and the equipment it controls must be turned off. Turning off the timer switch only will not prevent a shock hazard. Replace cover plate within housing before supplying power to time switch. Installation should be performed by a licensed electrician only. Before installing this product read all instructions carefully.

Remove protective cover panel within time switch housing by removing screws located above timer face and at the bottom of the cover panel.

Jumper Configuration

WARNING: Failure to properly configure the “Jumpers” will result in damage to the unit and void the warranty! Before installing and wiring the GE Time Switch, proper jumper configuration must be selected. This is accomplished as follows:

- 120VAC:** All four (4) “Jumpers” (J1, J2, J3 & J4) must be installed.
- 208/240VAC:** The two (2) “Middle Jumpers” (J1 & J3) must be installed and the two (2) “Outer Jumpers” (J2 & J4) must be removed.
- 277VAC:** All four (4) “Jumpers” must be removed.

To install or remove a “Jumper”, gently Pull-Off-Of or Push-On-To the respective pair of metal prongs which are located on the printed circuit board to the lower left of the clock module. Care must be taken to avoid bending or breaking the metal prongs and/or fastening the jumper to the incorrect pair. Once this step is complete the remainder of the installation can begin.

WARNING

Risk of electric shock

- Shut off power at fuse box or circuit breaker box before installation
- Do not use in wet locations
- Use indoors only

Risk of fire

- Do not use to control receptacle outlets
- Do not exceed electrical ratings
- Use copper wire only with this device

1. Remove 2 screws retaining the interior cover panel and remove panel by prying out with a thin blade at the top.
2. Select knockouts to be used. Remove the inner (1/2") knockout by inserting a screwdriver in the slot and carefully punch knockout loose. Remove slug. If the 3/4" knockout is required, remove the outer ring with pliers after removing the 1/2" knockout. Smooth edges with knife if necessary.
3. Place enclosure in desired mounting location and mark the three mounting holes.
4. Drill holes for #10 screws, start screws in holes.
5. Place enclosure over screws and tighten screws.
6. Connect conduit hubs to conduit before connecting the hubs to the enclosure. After inserting hubs into enclosure, carefully tighten hub lock nut. Do not over-tighten.
7. Install in accordance with all applicable National and Local code requirements.
8. Replace interior cover panel and 2 screws.

GROUNDING: This enclosure is of plastic construction and does not require a ground connection and does not require bonding in pool applications.

This enclosure does not provide grounding between conduits. When using non-metallic conduit or cable, connect the ground wires of all cables together with a wire nut. When metallic conduit is used, use grounding type bushings and a jumper wire between each conduit.

OPERATING INSTRUCTIONS:

When the Time Switch is installed and power applied, the timer's dial will turn clockwise maintaining time. The pointer on the face of the dial points to the current time

1. Locate the segments around on the outer edge of the timer's dial. These segments, each representing 30 minutes, can be pushed down and away from the edge of the dial (try using the tip of a pen or pencil). Conversely, segments that have been pushed down can be easily pushed back up by hand. Be sure all segments are pushed up before programming. Select a time period (or periods) you want the device turned on, then push down ALL the segments that fall on or within that time period. For example, to have the timer turn a device on at 10PM and off at 2AM, push down the segments representing 10PM and 2AM, and ALL the segments in between. You may need to turn the dial clockwise to access the desired segments.
2. Rotate the timer's dial clockwise until the pointer on the face of the dial points to the current time of day. Note: Nighttime hours (from 6PM to 5AM) are highlighted with a grey background.
3. Set master switch to the TIMER position.
4. To override timer program and control output load manually:
 - set master switch to OFF (center position) to turn load OFF
 - set master switch to ON (bottom position) to turn load ON
5. Disconnect power at fuse box or circuit breaker before removing panel or servicing connected equipment.

In case of power failure, reset the time of day as explained in step 2.

Typical Wiring Diagrams—SPDT

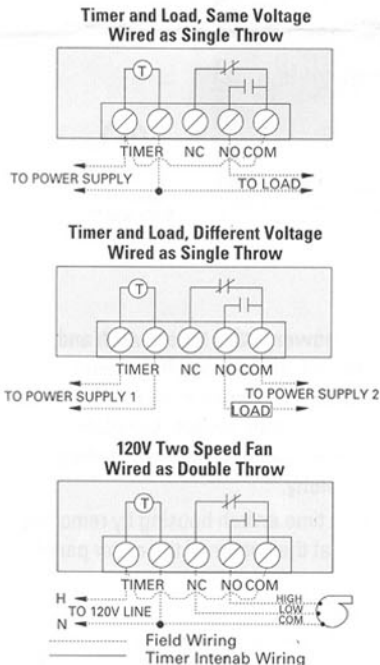

Typical Wiring Diagrams—DPDT

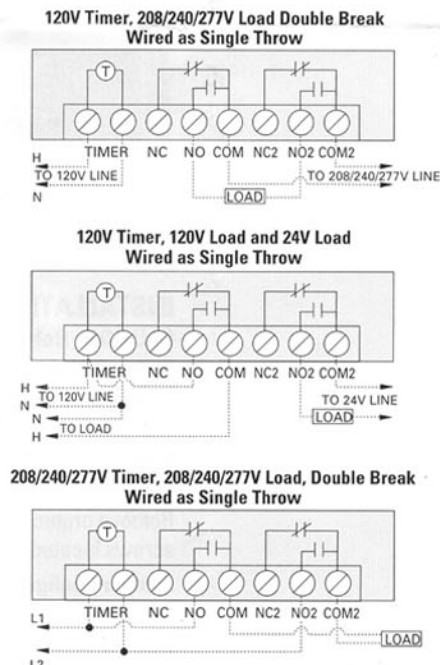

Timer Dial



Shows timer set to turn device ON at 10 PM and OFF at 2 AM. Notice ALL segments between 10 PM and 2 AM have been pushed out. Current time is 9:00 PM.