

DIY KIT 101. FUNCTION GENERATOR

INTRODUCTION

This compact function generator provides sine, square and triangular waveforms up to 20MHz over three ranges using “course” and “fine” frequency adjustment controls. The output level is adjustable from 0-2Vp-p. A TTL output is also provided for connection to a frequency counter. BNC output connectors are used. The kit comes complete with a plastic case (140 x 35 x 110 mm) and pre-punched, silk-screened front and rear panels. The kit is powered from a 7-12V AC plug pack (not supplied).

This kit was designed by *David L. Jones* and published in *Electronics Australia, August 1996*. The schematic is unchanged except for the AC power source. We have repackaged it to fit into a different plastic case, making it easier to construct. We have included a copy of the original magazine article. Refer to this article for a description of how the unit works. Ignore the construction details in the article and use the “Assembly Instructions” below instead.

The kit is constructed on a single-sided printed circuit board (PCB). Protel Autotrax & Schematic were used to design the board.

ASSEMBLY INSTRUCTIONS

Follow the component overlay on the PCB to insert components.

The board requires three links. Start by fitting the resistors first. Keep the resistor lead offcuts and use them for the wire links. Next fit the diodes and all the capacitors (except electrolytics). The IC sockets are next.

Insert the two voltage regulators, taking care to fit them into their correct positions. Before soldering, fit the heatsinks to the regulators using the screws and nuts provided. The heatsinks should not be touching. Next comes the BNC connectors and the DC jack. Make sure they are sitting right down on the PCB before soldering.

Next fit the two toggle switches, once again making sure they are pushed right down before soldering. All that remains is the electrolytic capacitors and the potentiometers. The electrolytics are polarity sensitive. Use the polarity marks on the PCB to position them correctly.

Last is the “power on” LED. Strip the ends of each of the wires supplied and solder one end of each wire into the holes provided on the PCB. Fit the LED to the front panel and solder the other end of each wire to the proper lead on the LED (long leg is positive, short is catode).

Before connecting power, double check that all components are in their correct positions and that all component leads are soldered. Inspect all solder connections for “dry joints”. This is the most common cause of kits not working properly. Note two resistors may be marked wrongly on the PCB overlay: R3 should be 820R and R6 should be 6R8. This will be fixed next run.

Before installing any ICs on the board, apply power and make sure that you get +5V and -5V on the power pins of each of the Ics. If all is well, remove the power and fit the ICs.

Fit the front and rear panels onto the assembled PCB and hold them in position. Now mount the PCB onto the bottom half of the plastic case. The front and rear panels should slide into slots at the front and rear of the case. Once the panels are in place, use the self-tapping screws to fix the PCB to the case. Do NOT overtighten.

PARTS LIST - KIT 101

Resistors (0.24W,2%)

6R8 blue grey black silver.....	R6.....	1
47 yellow violet black gold	R9,10.....	2
330 orange orange black black.....	R5.....	1
560 green blue black black.....	R11.....	1
820 grey red black black.....	R3.....	1
1K brown black black brown.....	R2,4.....	2
3K3 orange orange black brown.....	R1.....	1
10K brown black black red.....	R7,8.....	2
1K potentiometers	VR1,2,3.....	3
PCB mounting, linear		

Capacitors

27pF ceramic	C7.....	1
10nF ceramic	C6.....	1
100nF ceramic	C8-C18.....	11
1uF 16V mini electro.....	C5.....	1
10uF 16V mini electro.....	C3,4.....	2
1000uF 25V electro.....	C1,2.....	2

Semiconductors

1N4004.....	D1,2.....	2
7805, +5V regulator	REG2.....	1
7905, -5V regulator	REG1.....	1
EL2001.....	IC3.....	1
70MHz unity gain buffer		
MAX038.....	IC1.....	1
Waveform generator		
TL072.....	IC2.....	1
Dual JFET-input op amp		
Panel mounting LED		1

Miscellaneous

SPDT toggle switch.....	S1,2.....	2
PCB mounting, C&K 7103-AV2		
2.5mm DC jack.....	X1.....	1
PCB mounting		
BNC connectors	SK1,2.....	2
Right angle, PCB mounting		
IC socket, 20 pin.....		1
IC socket, 8 pin.....		2
K101 PCB		1
Front & Rear panels.....		1 set
Plastic case		1
Plastic knobs.....		3
Heatsinks HS103		2
3 x 6 mm screws & nuts.....		2
Self-tapping screws.....		6
Twin Ribbon Wire, 4"/10cm long		1

DIY KIT 101. FUNCTION GENERATOR

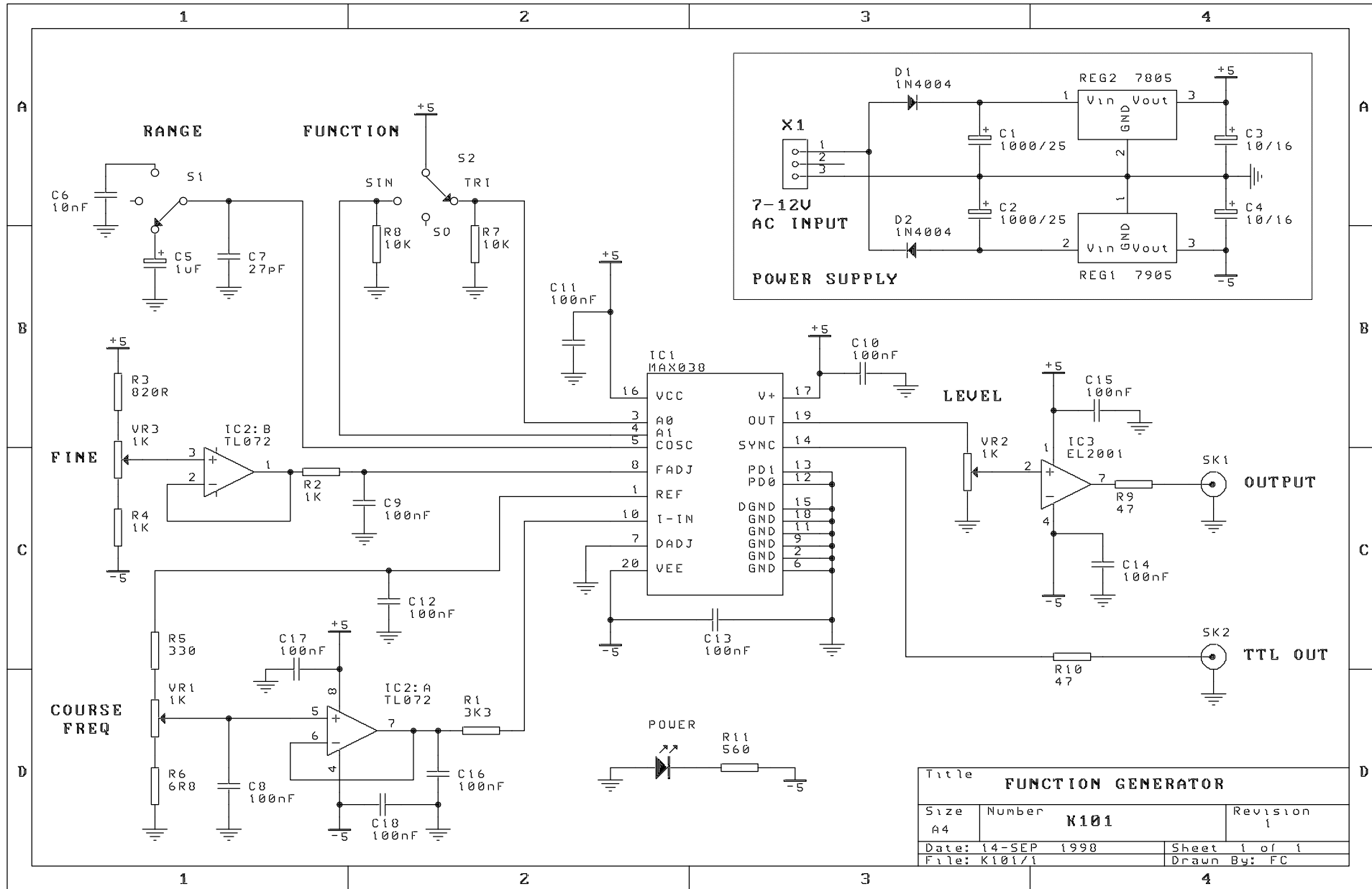

Title		
FUNCTION GENERATOR		
Size	Number	Revision
A4	K101	1
Date: 14-SEP 1998		Sheet 1 of 1
File: K101/1		Drawn By: FC