

Digital Storage Oscilloscope

GDS-1000 Series

USER MANUAL

GW INSTEK PART NO. 82DS-11020Mo1



ISO-9001 CERTIFIED MANUFACTURER

GW INSTEK

This manual contains proprietary information, which is protected by copyrights. All rights are reserved. No part of this manual may be photocopied, reproduced or translated to another language without prior written consent of Good Will company.

The information in this manual was correct at the time of printing. However, Good Will continues to improve products and reserves the rights to change specification, equipment, and maintenance procedures at any time without notice.

Good Will Instrument Co., Ltd.
No. 7-1, Jhongsing Rd., Tucheng City, Taipei County 236, Taiwan.

Table of Contents

SAFETY INSTRUCTION	7
Safety Symbols	7
Safety Guidelines.....	8
Power cord for the United Kingdom.....	10
GETTING STARTED	11
GDS-1000 Series Overview	11
Series lineup.....	11
Main Features.....	12
Panel Overview.....	13
Front Panel	13
Rear Panel.....	16
Display.....	17
Set Up	18
QUICK REFERENCE	20
Menu Tree / Operation Shortcuts	20
Convention	20
Acquire key	20
Autoset key	21
CH1/2 key.....	21
Cursor key.....	22
Display key.....	22
Hardcopy key.....	23
Help key.....	23
Horizontal menu key.....	23
Math key	24
Measure key.....	25
Run/Stop key	25
Save/Recall key.....	26
Trigger key	30
Utility key	32
Default Settings.....	35
Built-in Help.....	36
MEASUREMENT	37

Basic Measurement	37
Channel activation	37
Autoset	38
Run/Stop	39
Horizontal position/scale	40
Vertical position/scale	40
Probe compensation signal	41
Automatic Measurement	43
Measurement items.....	43
Measurement.....	45
Cursor Measurement	46
Use horizontal cursor	46
Use vertical cursor	47
Math Operation	48
Overview.....	48
Addition/Subtraction	49
FFT.....	50
CONFIGURATION	51
Acquisition	51
Select acquisition mode.....	51
Real time vs Equivalent time sampling mode.....	53
Display	54
Select waveform drawing (vector/dot)	54
Accumulate waveform	54
Set display contrast.....	54
Freeze the waveform (Run/Stop)	55
Select display grid	55
Horizontal View.....	56
Move waveform position horizontally	56
Select horizontal scale	56
Select waveform update mode	57
Zoom waveform horizontally.....	58
Show waveform in X-Y mode.....	59
Vertical View (Channel)	60
Move waveform position vertically.....	60
Select vertical scale	60
Select coupling mode	61
Invert waveform vertically.....	61
Limit bandwidth	62
Select probe attenuation level	62
Trigger	64

Trigger type overview	64
Trigger parameter overview	64
Use edge trigger	66
Use video trigger	67
Use pulse width trigger	68
Use single trigger mode	70
Force trigger level to 50% of input signal amplitude	70
System Setting	71
View system information	71
Select menu language	71
SAVE/RECALL.....	72
File Format/Utility	72
Display image file format	72
Waveform file format	72
Setup file format	74
SD card utility	75
Quick Save (HardCopy)	77
Save	79
File type/source/destination	79
Save panel setting	80
Save waveform	81
Save display image	82
Save All	83
Recall	86
File type/source/destination	86
Recall default panel setting	86
Recall reference waveform on the display	88
Recall panel setting	89
Recall waveform	90
MAINTENANCE	92
Vertical Resolution Calibration	92
Probe Compensation	93
FAQ.....	95
The input signal does not appear on the display.	95
I want to remove some contents from the display.....	95
The waveform does not update (frozen).	95
The probe waveform is distorted.	96
Autoset does not catch the signal well.	96







I want to clean up the cluttered panel settings.	96
The saved display image is too dark on the background.	96
The accuracy does not match the specification.	96
The SD card slot does not accept my card.	96
APPENDIX.....	97
Fuse Replacement.....	97
GDS-1000 Specification	98
Model-specific.....	98
Common	99
Declaration of Conformity	101

S SAFETY INSTRUCTION

This chapter contains important safety instructions that you must follow when operating GDS-1000 and when keeping it in storage. Read the following before any operation to insure your safety and to keep the best condition for GDS-1000.

Safety Symbols

These safety symbols may appear in this manual or on GDS-1000.

	WARNING	Warning: Identifies conditions or practices that could result in injury or loss of life.
	CAUTION	Caution: Identifies conditions or practices that could result in damage to GDS-1000 or to other properties.
	DANGER High Voltage	
	Attention Refer to the Manual	
	Protective Conductor Terminal	
	Earth (ground) Terminal	

Safety Guidelines

General Guideline



CAUTION

- Make sure the BNC input voltage does not exceed 300V peak.
- Never connect a hazardous live voltage to the ground side of the BNC connectors. It might lead to fire and electric shock.
- Do not place any heavy object on GDS-1000.
- Avoid severe impacts or rough handling that leads to damaging GDS-1000.
- Do not discharge static electricity to GDS-1000.
- Use only mating connectors, not bare wires, for the terminals.
- Do not block the cooling fan opening.
- Do not perform measurement at power source and building installation site (Note below).
- Do not disassemble GDS-1000 unless you are qualified as service personnel.

(Measurement categories) EN 61010-1:2001 specifies the measurement categories and their requirements as follows. GDS-1000 falls under category II.

- Measurement category IV is for measurement performed at the source of low-voltage installation.
- Measurement category III is for measurement performed in the building installation.
- Measurement category II is for measurement performed on the circuits directly connected to the low voltage installation.
- Measurement category I is for measurements performed on circuits not directly connected to Mains.

Power Supply



WARNING

- AC Input voltage: 100 ~ 240V AC, 47 ~ 63Hz
- The power supply voltage should not fluctuate more than 10%.
- Connect the protective grounding conductor of the AC power cord to an earth ground, to avoid electrical shock.

Fuse



WARNING

- Fuse type: T1A/250V
- Make sure the correct type of fuse is installed before power up.
- To ensure fire protection, replace the fuse only with the specified type and rating.
- Disconnect the power cord before fuse replacement.
- Make sure the cause of fuse blowout is fixed before fuse replacement.

Cleaning GDS-1000

- Disconnect the power cord before cleaning.
- Use a soft cloth dampened in a solution of mild detergent and water. Do not spray any liquid.
- Do not use chemical containing harsh material such as benzene, toluene, xylene, and acetone.

Operation Environment

- Location: Indoor, no direct sunlight, dust free, almost non-conductive pollution (Note below)
- Relative Humidity: < 80%
- Altitude: < 2000m
- Temperature: 0°C to 50°C

(Pollution Degree) EN 61010-1:2001 specifies the pollution degrees and their requirements as follows. GDS-1000 falls under degree 2.

Pollution refers to “addition of foreign matter, solid, liquid, or gaseous (ionized gases), that may produce a reduction of dielectric strength or surface resistivity”.

- Pollution degree 1: No pollution or only dry, non-conductive pollution occurs. The pollution has no influence.
- Pollution degree 2: Normally only non-conductive pollution occurs. Occasionally, however, a temporary conductivity caused by condensation must be expected.
- Pollution degree 3: Conductive pollution occurs, or dry, non-conductive pollution occurs which becomes conductive due to condensation which is expected. In such conditions, equipment is normally protected against exposure to direct sunlight, precipitation, and full wind pressure, but neither temperature nor humidity is controlled.

Storage environment

- Location: Indoor
- Relative Humidity: < 85%
- Temperature: 0°C to 50°C

Power cord for the United Kingdom

When using GDS-1000 in the United Kingdom, make sure the power cord meets the following safety instructions.

NOTE: This lead/appliance must only be wired by competent persons



WARNING: THIS APPLIANCE MUST BE EARTHED

IMPORTANT: The wires in this lead are coloured in accordance with the following code:

- Green/ Yellow: Earth
- Blue: Neutral
- Brown: Live (Phase)



As the colours of the wires in main leads may not correspond with the colours marking identified in your plug/appliance, proceed as follows:

The wire which is coloured Green & Yellow must be connected to the Earth terminal marked with the letter E or by the earth symbol  or coloured Green or Green & Yellow.

The wire which is coloured Blue must be connected to the terminal which is marked with the letter N or coloured Blue or Black.

The wire which is coloured Brown must be connected to the terminal marked with the letter L or P or coloured Brown or Red.

If in doubt, consult the instructions provided with the equipment or contact the supplier.

This cable/appliance should be protected by a suitably rated and approved HBC mains fuse: refer to the rating information on the equipment and/or user instructions for details. As a guide, cable of 0.75mm² should be protected by a 3A or 5A fuse. Larger conductors would normally require 13A types, depending on the connection method used.

Any moulded mains connector that requires removal /replacement must be destroyed by removal of any fuse & fuse carrier and disposed of immediately, as a plug with bared wires is hazardous if engaged in live socket. Any re-wiring must be carried out in accordance with the information detailed on this label.

GETTING STARTED

This chapter describes GDS-1000 in a nutshell, including its main features and front / rear panel introduction. After going through the overview, follow the Set Up section to properly set up operation environment.

GDS-1000 Series Overview

Series lineup

Model name	Frequency bandwidth	Input channels
GDS-1022	DC – 25MHz (–3dB)	2
GDS-1042	DC – 40MHz (–3dB)	2
GDS-1062	DC – 60MHz (–3dB)	2
GDS-1102	DC – 100MHz (–3dB)	2





Main Features



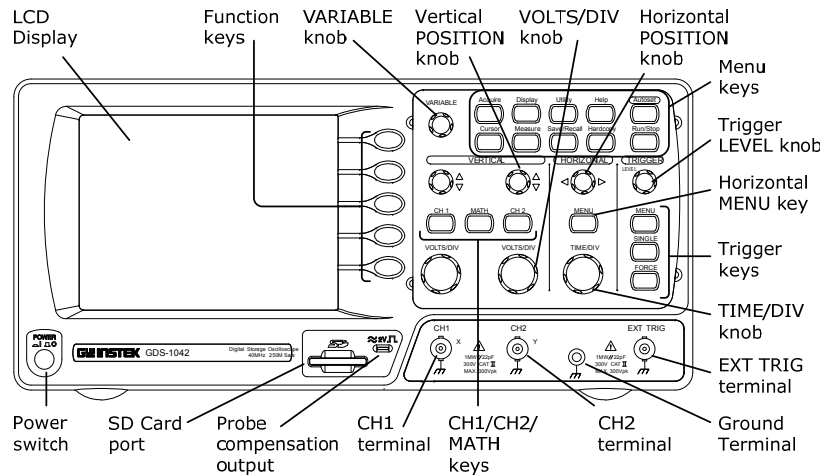











- | | |
|-------------|---|
| Performance | <ul style="list-style-type: none"> • 250MSa/S real-time sampling rate • 25GS/s equivalent-time sampling rate • 4k points record length per channel • Up to 10ns peak detection |
| Feature | <ul style="list-style-type: none"> • 5.6 inch color TFT display • Saving and recalling setups and waveforms • 18 types automatic measurements • 6-digit real-time frequency counter • Multi-language menu • Math operation: Add, Subtract, FFT • Edge, TV-line, Pulse Width trigger • Built-in Help • Compact size: (W) 310 x (D) 140 x (H) 142 mm |
| Interface | <ul style="list-style-type: none"> • SD card port for data saving/recalling • Calibration output • External trigger input |











Panel Overview

Front Panel

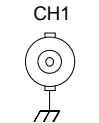

LCD display	TFT color, 320 x 234 resolution, wide angle view LCD display.
Function keys	 Activates the functions which appear on the left side of the LCD display.
Variable knob	 VARIABLE Increases/decreases value or move to the next/previous parameter.
Acquire key	 Acquire Configures acquisition mode (page51).
Display key	 Display Configures display settings (page54).

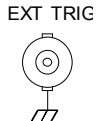
Utility key	 Utility Configures Hardcopy (page77), system info (page70), menu language (page71), calibration (page92), and probe compensation (page93).
Help key	 Help Shows Help contents on the LCD display (page36).
Autoset key	 Autoset Finds signals and sets the appropriate horizontal / vertical / trigger settings (page38).
Cursor key	 Cursor Runs cursor measurements (page46).
Measure key	 Measure Configures and runs automatic measurements (page43).
Save/Recall key	 Save/Recall Saves and recalls image, waveform, panel setup (page72).
Hardcopy key	 Hardcopy Transfers data to SD card (page77).
Run/Stop key	 Run/Stop Freezes the signal view (page39).
Trigger level knob	 TRIGGER LEVEL Sets the trigger level (page64).
Trigger menu key	 MENU Configures trigger settings (page64).
Single trigger key	 SINGLE Selects the single trigger mode (page70).
Trigger force key	 FORCE Forces the trigger level to 50% of the signal amplitude (page70).
Horizontal menu key	 MENU Configures horizontal view (page56).
Horizontal position knob	 Sets the horizontal position of waveforms (page56).

- TIME/DIV knob  Selects the horizontal scale (page56); Fine (clockwise) or coarse (counterclockwise).
- Vertical position knob  Sets the vertical position of waveforms (page60).
- CH1/CH2 key  Configures the vertical scale and coupling mode for each channel (page60).
- VOLTS/DIV knob  Selects the vertical scale (page60); Fine (clockwise) or coarse (counterclockwise).
- Input terminal  Accepts input signals: $1M\Omega \pm 2\%$ input impedance, BNC terminal.
- Ground terminal  Accepts the DUT ground lead for common ground.
- MATH key  Performs math operation (page48).
- SD card port  Facilitates transferring waveform data and display image (page72).
- Probe compensation output  Outputs 2Vp-p, square signal for probe compensation (page93) or demonstration.
- External trigger input  Accepts external trigger signal (page64).
- Power switch  Powers on or off the oscilloscope.

Rear Panel

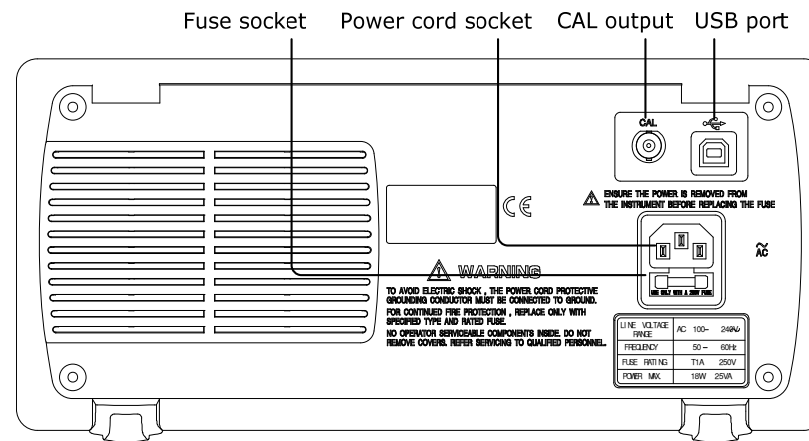

Power cord socket

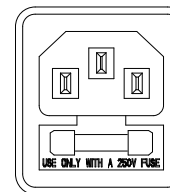

Power cord socket accepts AC mains, 100 ~ 240V, 50/60Hz.

Fuse socket

Fuse socket holds AC main fuse, T1A/250V.

For fuse replacement procedure, see page97.

USB slave port

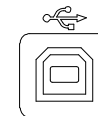

Accepts typeB male connector for PC software connection (reserved for future use).

Calibration output



Outputs the signal for vertical scale accuracy calibration (page92).

Display

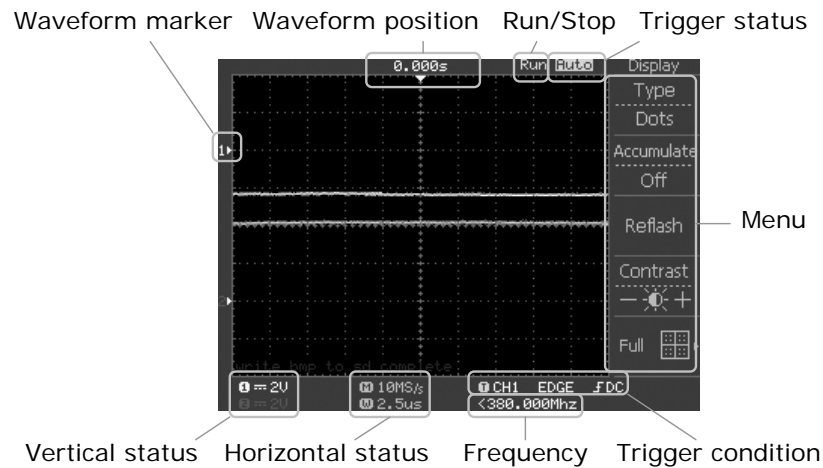

Waveforms	Shows input signal waveforms. Channel 1: Yellow Channel 2: Blue
Trigger status	Trig'd Triggered.
	Trig? Not triggered, display not updated.
	Auto Not triggered, display updated.
	STOP Trigger stopped. Also appears in Run/Stop (page39). For trigger details, see page64.
Input signal frequency	Shows the input signal frequency. “< 20Hz” Indicates that the frequency is less than 20Hz (lower frequency limit).
Trigger configuration	Shows the trigger source, type, and slope. In case of Video trigger, shows trigger source and polarity.
Channel status	Shows the channel, coupling mode, vertical scale, and horizontal scale. For channel details, see page60.

Set Up

Background

This section describes how to connect a signal, adjust the scale, and compensate the probe. Before operating GDS-1000 in a new environment, run these steps to make sure the oscilloscope is functionally stable and to help becoming familiar with it.

Steps

1. Connect the power cord to the rear panel socket.
2. Press the power switch. The display becomes active.
3. Reset the system by recalling the factory setting. Press the Save/Recall key, then Default Setup. For factory setting details, see page35.
4. Connect the probe to Channel1 input terminal and to the probe compensation signal output (2Vp-p, 1kHz square wave).
5. Set the probe attenuation to x10.

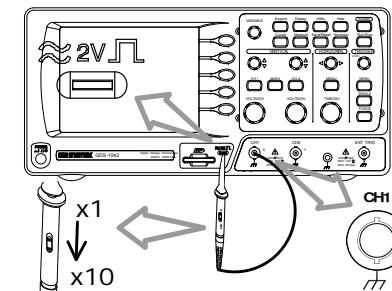
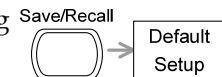
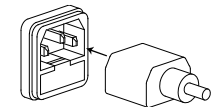

- Press the Autoset key. A square waveform appears on the center of the waveform. For Autoset details, see page38.



- Press the Display key, then *Type* to select vector waveform.

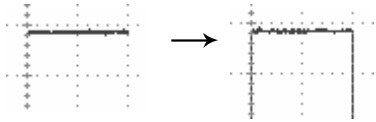
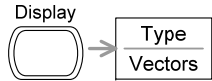

- Turn the adjustment point on the probe to make the square waveform edge flat.

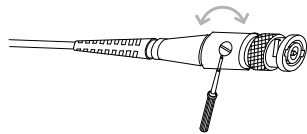
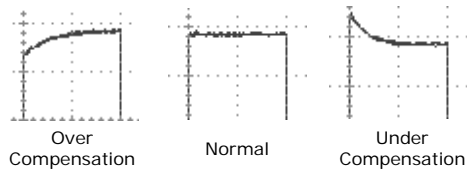

- Continue with other operations.

Measurements: page37 Configurations: page51

QUICK REFERENCE

This chapter describes GDS-1000 menu tree, shortcuts to major operations, built-in Help access, and default factory settings. Use them as a handy reference to get a quick access to the functionality.

Menu Tree / Operation Shortcuts

Convention

- Normal = Select Normal
- Average \leftarrow = Select Average repeatedly
- Normal ~ Average = Select one from Normal to Average and press it
- Normal \rightarrow VAR \odot = Press Normal, then use the Variable knob

Acquire key

<p>Acquire</p>	<p>Select acquisition mode</p> <p>Normal ~ Peak-Detect</p>								
<table border="1" style="border-collapse: collapse;"> <tr><td>Normal</td><td>\odot</td></tr> <tr><td>Average</td><td>\odot</td></tr> <tr><td>Peak-Detect</td><td>\odot</td></tr> <tr><td>Off</td><td>\odot</td></tr> </table>	Normal	\odot	Average	\odot	Peak-Detect	\odot	Off	\odot	<p>Select average number</p> <p>Average \leftarrow</p> <p>Turn peak detect on/off</p> <p>Peak-Detect \leftarrow</p>
Normal	\odot								
Average	\odot								
Peak-Detect	\odot								
Off	\odot								
<table border="1" style="border-collapse: collapse;"> <tr><td>2/ 4/ 8/ 16/ 32/ 64/ 128/ 256</td></tr> </table>	2/ 4/ 8/ 16/ 32/ 64/ 128/ 256								
2/ 4/ 8/ 16/ 32/ 64/ 128/ 256									
<table border="1" style="border-collapse: collapse;"> <tr><td>On/ Off</td></tr> </table>	On/ Off								
On/ Off									
<table border="1" style="border-collapse: collapse;"> <tr><td>Mem Leng</td></tr> <tr><td>4k</td></tr> </table>	Mem Leng	4k							
Mem Leng									
4k									

Autoset key



Automatically find signal and set scale Autoset

CH1/2 key

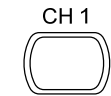

Turn on/off channel CH 1/2

Coupling

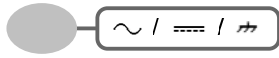

Select coupling mode Coupling

Invert Off

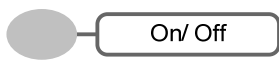

Turn waveform invert On/Off Invert

BW Limit Off

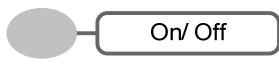

Turn bandwidth limit On/Off BW Limit

Probe x1

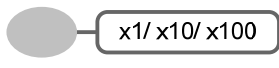

Select probe attenuation factor Probe

Cursor key



Turn on/off cursor Cursor

Source CH1



Select X or Y cursor X↔Y

X1 123.4us

X2 22.9us

X1X2 Δ:23.6us f:11.9Hz

X↔Y

Display key



Select waveform display type Type

Type Vectors



Waveform accumulate On/Off Accumulate, Refresh (refresh display when On)

Accumulate Off



Set display contrast Contrast→VAR

Refresh



Contrast



Select display grid

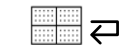
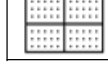

Hardcopy key

Hardcopy → See Utility key (page32)



Help key

Help Turn help mode On/Off
Help



Horizontal menu key

MENU	Select main (default) display
	Main
Main	Select Window mode and zoom
Window	Window → TIME/DIV, Window Zoom
Window Zoom	Select windows roll mode
Roll	Roll
XY	Select XY mode
	XY

Math key

MATH	Select math operation type (+/-) Operation
	Operation
+	Select addition/subtraction CH1+/-CH2
CH1+CH2	Set result position Position → VAR
	Math result Volt/Div Unit/Div → VAR
Position	
0.00 Div	-12div ~ +12div
Unit/Div	
2V	2mV/div ~ 5V/div

Math key (cont.)

MATH	Select math operation type (FFT) Operation
	Operation
FFT	Select FFT source channel Source
Source	Select FFT window Window
CH1	Select FFT result position Position → VAR
Window	Select vertical scale Unit/Div
Hanning	
	Flattop/Rectangular/Blackman/Hanning
Position	
0.00 Div	-12div ~ +12div
Unit/Div	
1dB	20/10/5/2/1 dB

Measure key

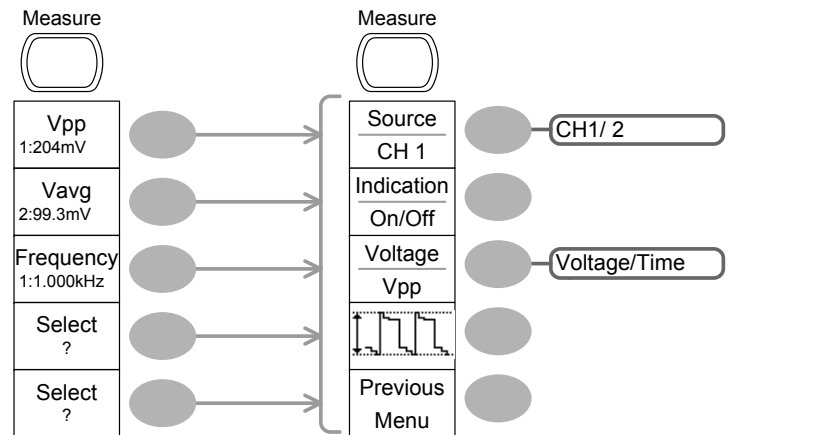

Turn on/off measurement	Measure
Select source channel	Source
Display measurement result	Indication
Select measurement type	Voltage/Time
Select measurement item	VAR or Icon
Go back to previous menu	Previous Menu

Run/Stop key

Run/Stop	Freeze/unfreeze waveform or trigger Run/Stop
----------	---

Save/Recall key

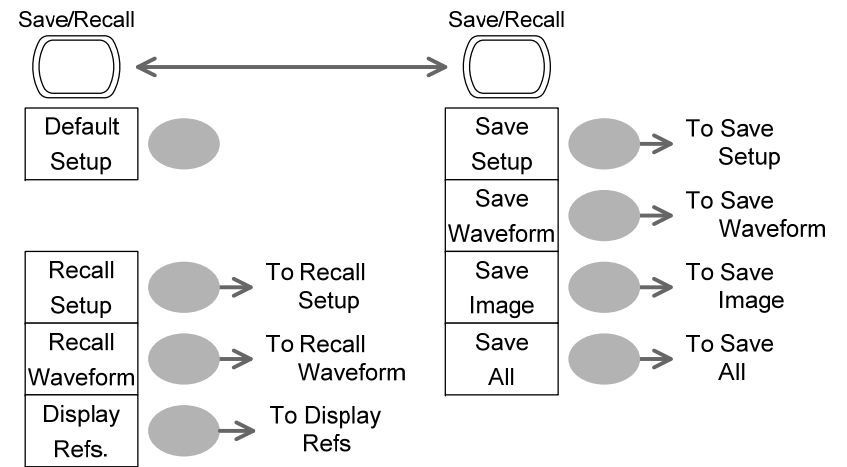

Select Save or Recall menu	Save/Recall
Recall default setup	Default Setup

Save/Recall key (cont.)

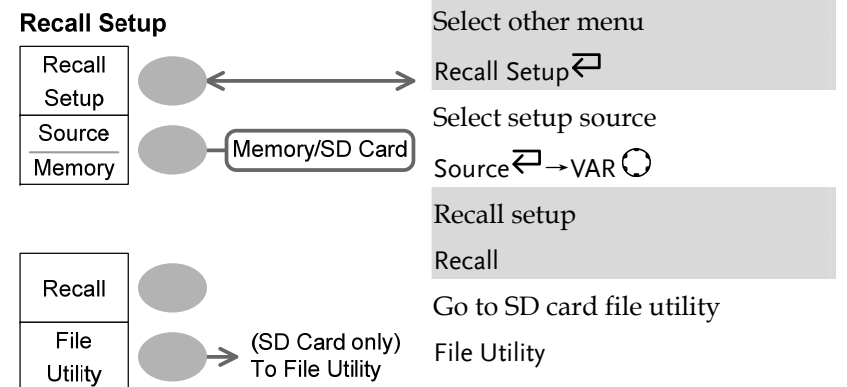

Recall Setup	Select other menu
Source Memory	Recall Setup
File Utility	Select setup source Source → VAR
	Recall setup
	Recall
	Go to SD card file utility
	File Utility

Save/Recall key (cont.)

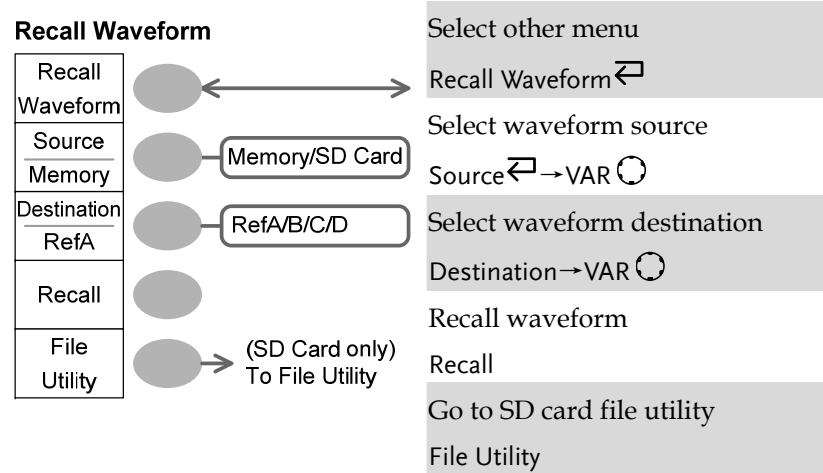

Save/Recall key (cont.)

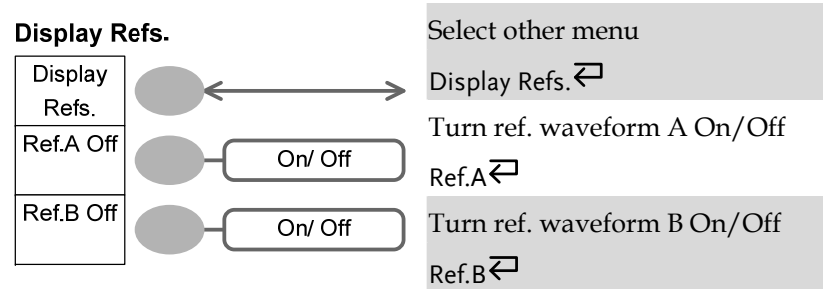

Save/Recall key (cont.)

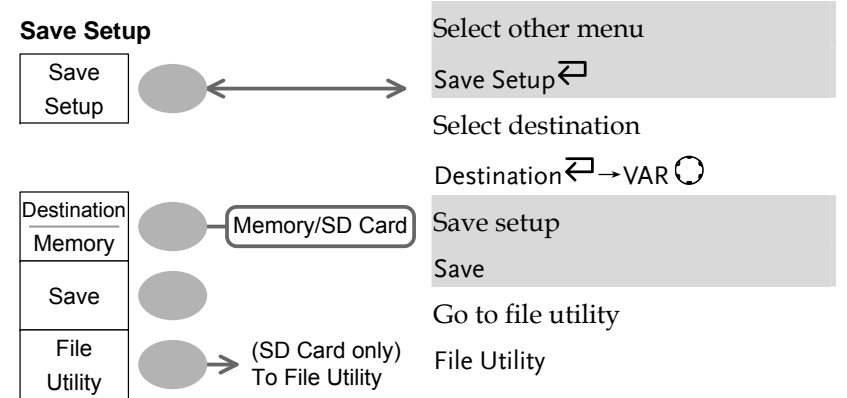

Save/Recall key (cont.)

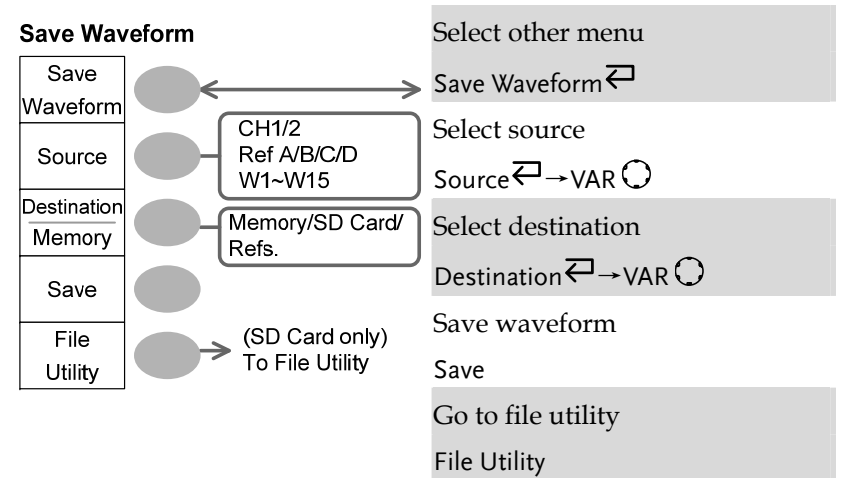

Save/Recall key (cont.)

Save Image

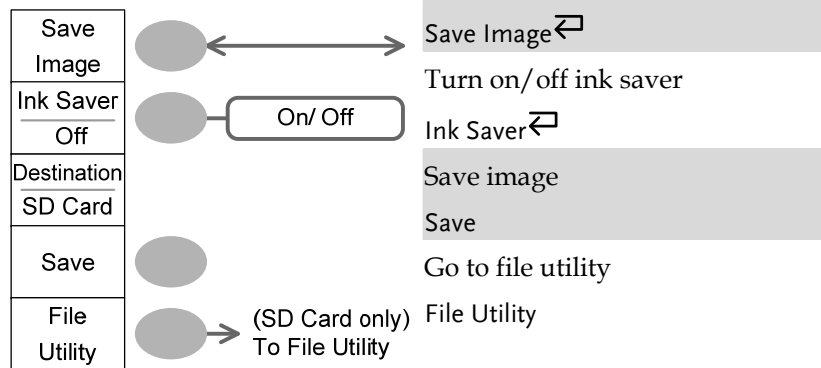

Save/Recall key (cont.)

Save All

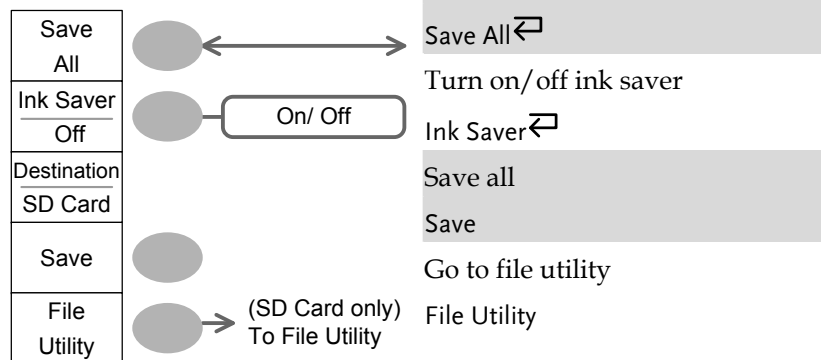

Save/Recall key (cont.)

File Utilities

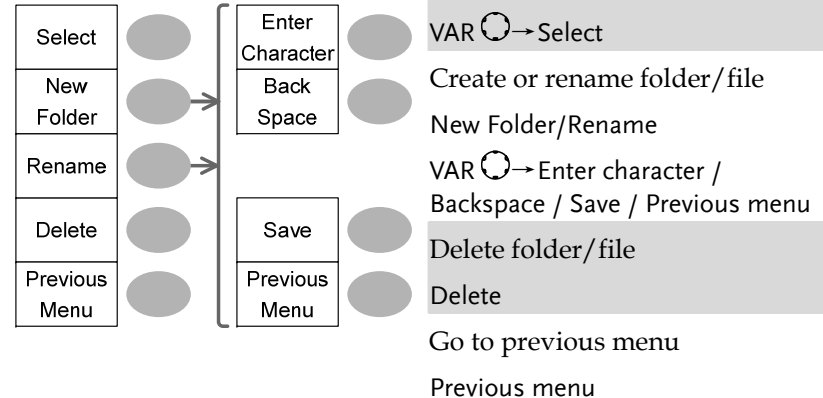

Trigger key

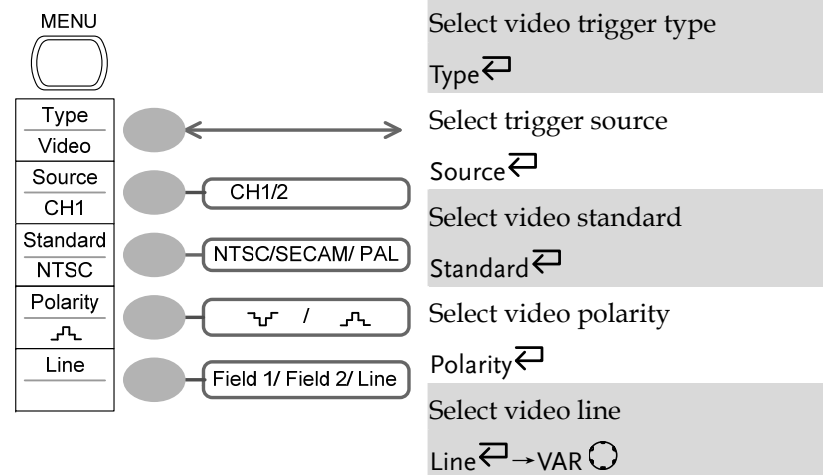

Trigger key (cont.)

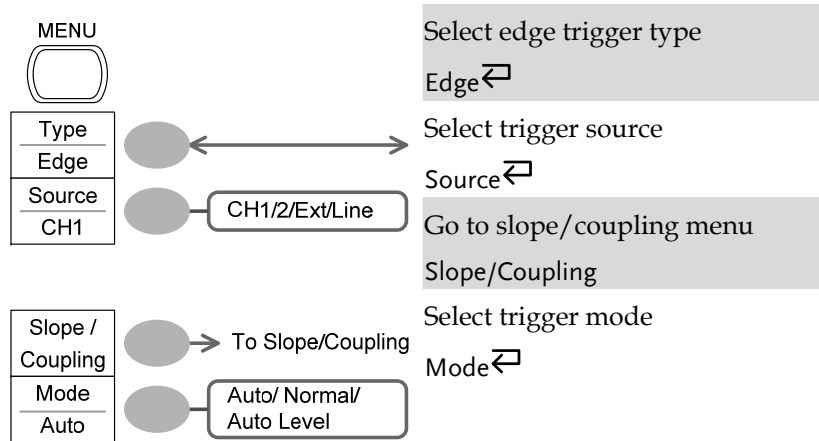

Trigger key (cont.)

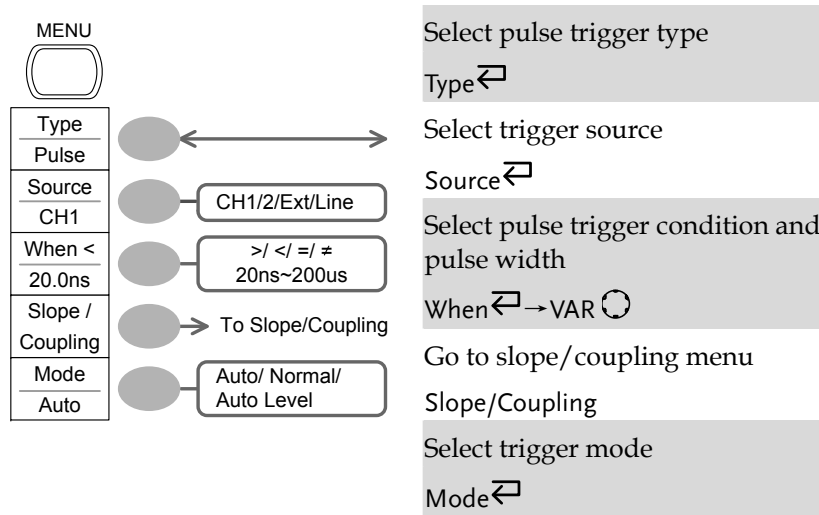

Trigger key (cont.)

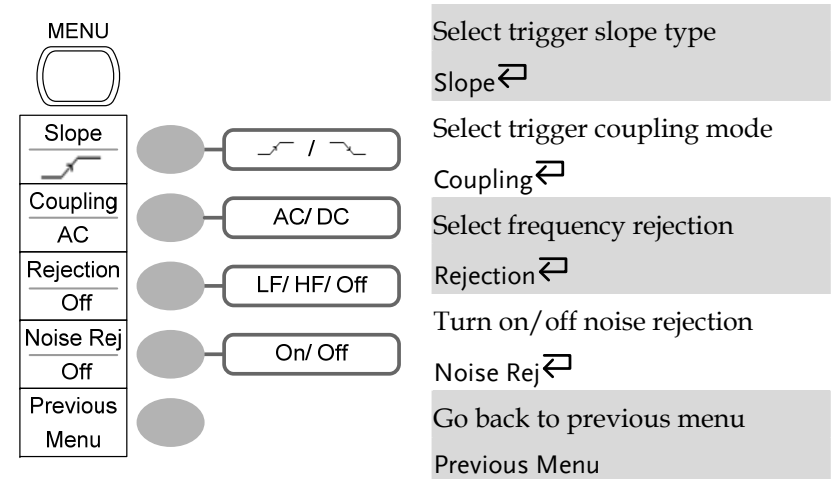

Utility key

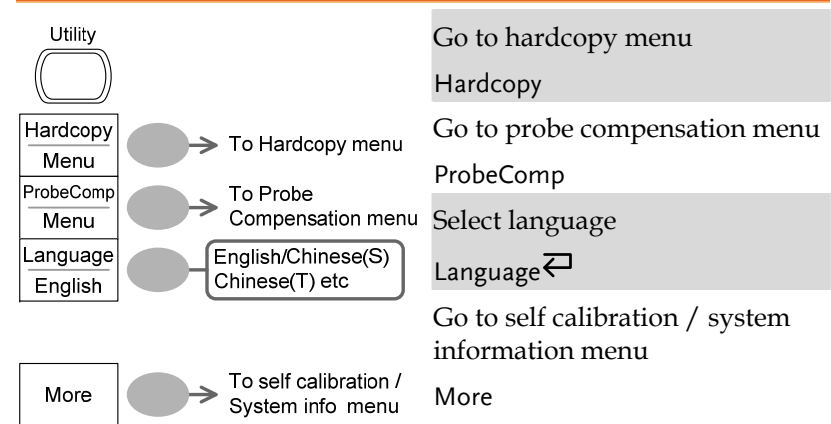

Utility key (cont.)

Calibration / System information

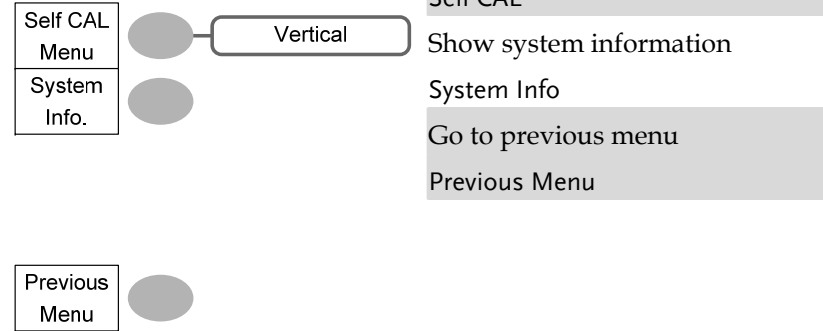

Utility key (cont.)

Hardcopy

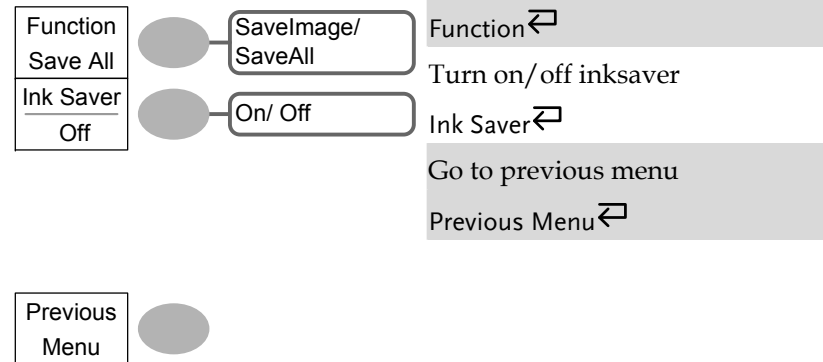

Utility key (cont.)

Probe compensation

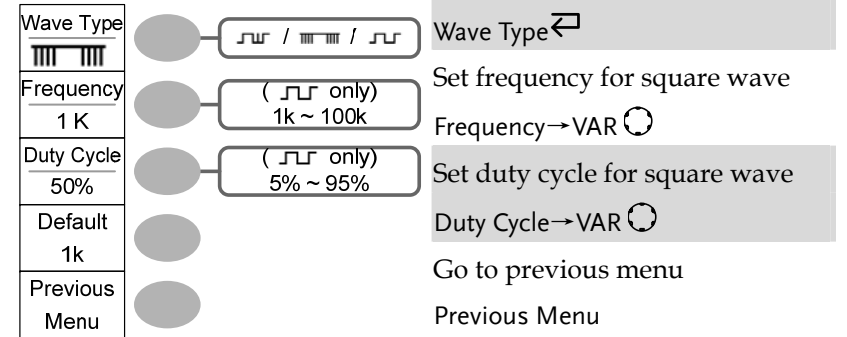

Default Settings

Here is the factory installed panel settings which appear when pressing the Save/Recall key → *Default Setup*.

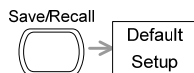

Acquisition	Mode: Normal	
Channel	Scale: 2V/Div	CH1: On, CH2: Off
	Coupling: DC	Invert: Off
	BW limit: Off	Probe attenuation: x1
Cursor	Source: CH1	Cursor: Off
Display	Type: Vectors	Accumulate: Off
	Graticule:	
Horizontal	Scale: 2.5us/Div	Mode: Main Timebase
Math	Type: + (Add)	Channel: CH1+CH2
	Position: 0.00 Div	Unit/Div: 2V
Measure	Source: CH1	Measurement: Off
Trigger	Type: Edge	Source: Channel1
	Mode: Auto	Slope:
	Coupling: DC	Rejection: Off
	Noise Rejection: Off	
Utility	SaveImage, InkSaver Off	Language: English
	Square wave probe, 1k, 50% duty cycle	Hardcopy: save image

Built-in Help

The Help key shows help contents. When each functional key is pressed, simple explanations of major functionalities appear on the display.



Applicable keys

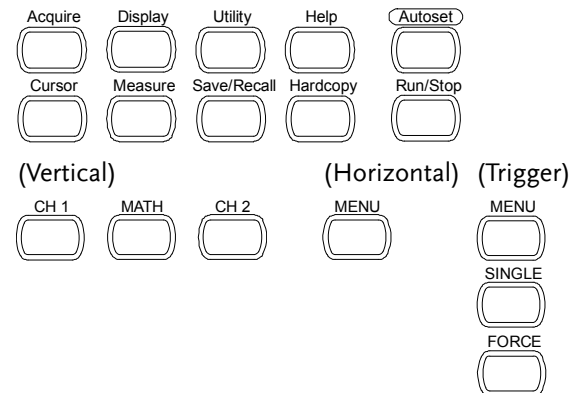

Panel operation

1. Press the Help key. The display changes to the Help mode.
2. Press each key to access its help contents. (example: Acquire key)
3. Use the Variable knob to scroll the Help contents up and down.
4. Press the Help key again to exit the Help mode.



MEASUREMENT

Basic Measurement

This section describes the basic operations required in capturing and viewing the input signal. For more detailed operations, see the following chapters.

- Measurements → from page37
- Configurations → from page51

Channel activation

Activate channel To activate an input channel, press the Channel key. The waveform appears on the display. 

De-activate channel To disable the channel, press the Channel key again. If the display menu is other than the Channel menu, press twice (the first pressing just activates the Channel menu). 

Default setup When the default setup is recalled (Save/Recall key → *Default Setup*), Channel 1 automatically turns On. Channel 2 becomes Off.

Autoset  The Autoset (page38) does NOT automatically activate the channels to which input signals are connected.

Autoset

Background Autoset function automatically configures the panel settings to position the input signal to the best viewing condition. GDS-1000 automatically configures the following parameters.

- Horizontal scale
- Vertical scale
- Trigger source channel

Panel operation 1. Connect the input signal to GDS-1000 and press the Autoset key. 

2. The waveform appears in the center of the display.

3. To undo Autoset, press *Undo*. This feature is available for 5 seconds after Autoset is activated. 

Limitation Autoset does not work in the following situation.

- Input signal frequency less than 20Hz
- Input signal amplitude less than 30mV

Run/Stop

Background By default, the waveform on the display is constantly updated (Run mode). Freezing the waveform (Stop mode) allows flexible observation and analysis. To enter the Stop mode, two methods are available: pressing the Run/Stop key or using Single Trigger mode.

Stop mode icon When in Stop mode, the Stop icon appears at the top of the display.

Freeze waveform by Run/Stop key 1. Press the Run/Stop key once. The waveform freezes. To unfreeze the waveform, press the Run/Stop key again.



Freeze waveform by Single Trigger mode 2. In the single trigger mode, the waveform always stays in the Stop mode, and is updated only when the Run/Stop key is pressed. For trigger details, see page64. Note: pressing the Run/Stop key only updates the waveform once - it does not switch to Run mode (continuous update).



Waveform operation The waveform can be moved or scaled in both Run and Stop mode, but in different manners. For details, see page56 (Horizontal position/scale) and page60 (Vertical position/scale).

Horizontal position/scale

For more detailed configuration, see page56.

Set horizontal position The horizontal position knob moves the waveform left/right.

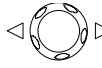

Select horizontal scale To select the timebase (scale), turn the TIME/DIV knob; left (slow) or right (fast).



Range 1ns/Div ~ 10s/Div, 1-2-5 increment

The corresponding sampling rate appears on the upper side of the display. The timebase indicator appears on the lower side.

Stop mode In the Stop mode, the memory bar and waveform size changes according to the scale.

Vertical position/scale

For more detailed configuration, see page60.

Set vertical position To move the waveform up or down, turn the vertical position knob for each channel.



As the waveform moves, the vertical position of the cursor appears at the bottom left corner of the display.

Run/Stop mode The waveform can be moved vertically in both Run and Stop mode.

Select vertical scale To change the vertical scale, turn the VOLTS/DIV knob; left (down) or right (up).



Range 2mV/Div ~ 5V/Div, 1-2-5 increments



The vertical scale indicator for each channel on the bottom left of the display changes accordingly.

Stop mode In Stop mode, the vertical scale setting can be changed but the waveform shape stays the same.

Probe compensation signal

Background This section introduces how to use the probe compensation signal for general usage, in case the DUT signal is not available or to get a second signal for comparison. For probe compensation details, see page93.





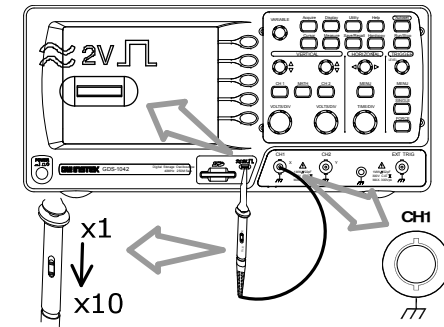

Note that the frequency accuracy and duty factor are not guaranteed. Therefore the signal should not be used for reference purpose.

Waveform type		Square waveform used for probe compensation. 1k ~ 100kHz, 5% ~ 95%.
		Demonstration signal for showing the effects of peak detection. See page51 for peak detection mode details.
		Demonstration signal for showing the effects of long memory.

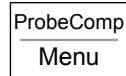
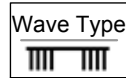
View compensation 1. Connect the probe between the compensation signal output and Channel input.

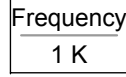
waveform

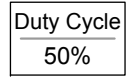

2. Press the Utility key. 
3. Press *ProbeComp*. 
4. Press Wave type repeatedly to select the wave type. 
5. (For  only) To change the frequency, press *Frequency* and use the Variable knob. 

 Range 1kHz ~ 100kHz
6. (For  only) To change the duty cycle, press *Duty Cycle* and use the Variable knob. 

 Range 5% ~ 95%

Probe compensation For probe compensation details, see page93.

Automatic Measurement

Automatic measurement function measures and updates major items for Voltage, Time, and Delay type.

Measurement items

Overview	Voltage type	Time type
	Vpp	Frequency
	Vmax	Period
	Vmin	RiseTime
	Vamp	FallTime
	Vhi	+Width
	Vlo	-Width
	Vavg	Dutycycle
	Vrms	
	ROVShoot	
	FOVShoot	
	RPREShoot	
	FPREShoot	
Voltage measurement	Vpp	Difference between positive and negative peak voltage (=Vmax - Vmin)
	Vmax	Positive peak voltage.
	Vmin	Negative peak voltage.
	Vamp	Difference between global high and global low voltage (=Vhi - Vlo)
	Vhi	Global high voltage.

Vlo		Global low voltage.
Vavg		Averaged voltage of the first cycle.
Vrms		RMS (root mean square) voltage.
ROVShoot		Rise overshoot voltage.
FOVShoot		Fall overshoot voltage.
RPREShoot		Rise preshoot voltage.
FPREShoot		Fall preshoot voltage.

Time measurement	Item	Description
	Freq	Frequency of the waveform.
	Period	Waveform cycle time (=1/Freq).
	Risetime	Rising time of the pulse (~90%).
	Falltime	Falling time of the pulse (~10%).
	+Width	Positive pulse width.
	-Width	Negative pulse width.
	Duty Cycle	Ratio of signal pulse compared with whole cycle =100x (Pulse Width/Cycle)

Measurement

View measurement result

1. Press the Measure key.
2. The Channel 1 and Channel 2 measurement results appear on the menu bar, constantly updated. Press the menu to change the measurement item for each location.



Select measurement item

1. The selection menu appears. Press *Source* repeatedly to select the first source channel.
2. Press the third menu repeatedly to select the measurement type: *Voltage* or *Time*.
3. Use the Variable knob or press the icon repeatedly to select the measurement item.
4. Press *Previous Menu* to confirm the item selection and to go back to the measurement results view.

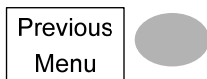
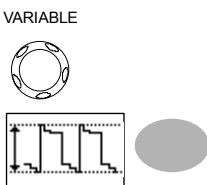
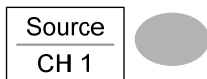

Indication mode

Pressing *Indication* and turning on the indication mode allows the measurement result appear in the display regardless of the menu contents.



Cursor Measurement

Cursor line, horizontal or vertical, shows the position and value of the waveform and math operation result.

Use horizontal cursor

Panel operation/ Range

1. Press the Cursor key to activate the cursors which appear in the display.
2. Press *Source* repeatedly to select the source channel.
3. Press *X↔Y* to select the horizontal (X1&X2) cursor.
4. The cursor position information appears in the menu.

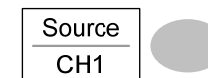

Range CH1, 2, Math

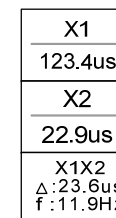
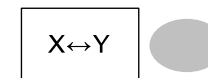

Parameter

- X1 Time position of the left cursor
- X2 Time position of the right cursor
- Δ The time distance between the left and right cursor
- f The time distance (Δ) converted to frequency

- Use the Variable knob to move the cursor left or right. The contents changes accordingly.



Use vertical cursor

Panel operation/
Range

- Press the Cursor key.



- Press *Source* repeatedly to select the source channel.

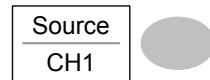

Range CH1, 2, Math

- Press X↔Y to select the vertical (Y1&Y2) cursor.

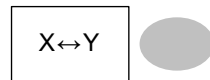

- The cursor position information appears on the menu.

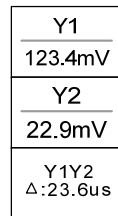

Parameter

- Y1 Voltage level of the upper cursor
- Y2 Voltage level of the lower cursor
- Δ The voltage difference between the upper and lower cursor

- Use the Variable knob to move the cursor up or down.







Math Operation

Overview



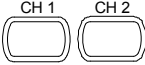

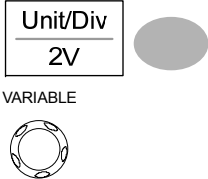
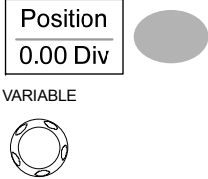

Background	Math operation runs addition, subtraction, or FFT for the input signals and shows the result on the display. The resulted waveform characteristics can be measured using the cursors.	
Addition (+)	Adds amplitude of CH1 & CH2 signals.	
Subtraction (-)	Extracts the amplitude difference between CH1 & CH2.	
FFT	Runs FFT calculation on a signal. Four types of FFT windows are available: Hanning, Flattop, Rectangular, and Blackman.	
Hanning FFT window	Frequency resolution	Good
	Amplitude resolution	Not good
	Suitable for...	Frequency measurement on periodic waveform
Flattop FFT window	Frequency resolution	Not good
	Amplitude resolution	Good
	Suitable for...	Amplitude measurement on periodic waveform
Rectangular FFT window	Frequency resolution	Very good
	Amplitude resolution	Bad
	Suitable for...	Single-shot phenomenon (this mode is the same as having no window at all)

Blackman FFT window	Frequency resolution	Bad
	Amplitude resolution	Very good
	Suitable for...	Amplitude measurement on periodic waveform

Addition/Subtraction

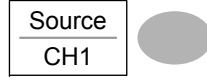
- Panel operation
1. Activate both CH1 and CH2. 
 2. Press the Math key. 
 3. Press *Operation* repeatedly to select addition (+) or subtraction (-). 
 4. The math measurement result appears in the display. Press the vertical scale of math waveform (Unit/div) and use the Variable knob. 
 5. To move the math waveform vertically, press *Position* and use the Variable knob. 
 6. To clear the math result from the display, press the Math key again. 

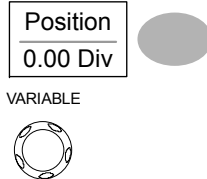
FFT

- Panel operation
1. Press the Math key. 
 2. Press *Operation* repeatedly to select FFT. 
 3. Press *Source* repeatedly to select the source channel. 
 4. Press *Window* repeatedly to select the FFT window type. 
 5. The FFT result appears. For FFT, the horizontal scale changes from time to frequency, and the vertical scale from voltage to dB.
 6. To move the FFT waveform vertically, press *Position* and use the Variable knob. 
Range -12.00 Div ~ +12.00 Div
 7. To select the vertical scale of FFT waveform, press *Unit/Div* repeatedly. 
Range 1, 2, 5, 10, 20 dB/Div
 8. To clear the FFT result from the display, press the Math key again. 

CONFIGURATION

Acquisition

Acquisition process samples the analog input signals and converts them into digital format for internal processing.

Select acquisition mode

Panel operation 1. Press the Acquire key.



2. Select the acquisition mode between *Normal* and *Average*.

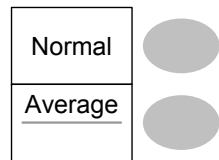

Range	Normal	Average
	All of the acquired data is used to draw the waveform.	Multiple acquired data are averaged. This mode is useful for drawing a noise-free waveform. To select the number, press Average repeatedly. Average number: 2, 4, 8, 16, 32, 64, 128, 256

3. To activate the Peak detect mode, press *Peak-Detect*. Only the minimum and maximum value pairs for each acquisition interval (bucket) are used. This mode is useful for catching abnormal glitches in the signal.

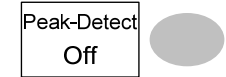

Peak detect effect using probe comp. waveform

1. One of the probe compensation waveforms can demonstrate peak detection mode. Connect the probe to the probe compensation output.



2. Press the Utility key.



3. Press *ProbeComp*.

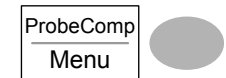

4. Press *Wave Type* and select the \square waveform.

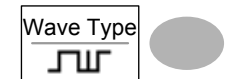

5. Press the Autoset key. GDS-1000 positions the waveform in the center of the display.



6. Press the Acquire key.



7. Press *Normal*.



- Press *Peak-Detect* and see that a spike noise is captured.

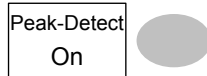

Real time vs Equivalent time sampling mode

Background	GDS-1000 automatically switches between two sampling modes, Real-time and Equivalent-time, according to the number of active channel and sampling rate.	
Parameter	Real-time sampling	One sampled data is used to reconstruct a single waveform. Short-time events might get lost if the sampling rate gets too high. This mode is used when the sampling rate is relatively low.
	Equivalent-time sampling	Multiple numbers of sampled data are accumulated to reconstruct a single waveform. Restores greater waveform details but takes longer to update the waveform. This mode is used when the sampling rate becomes higher.

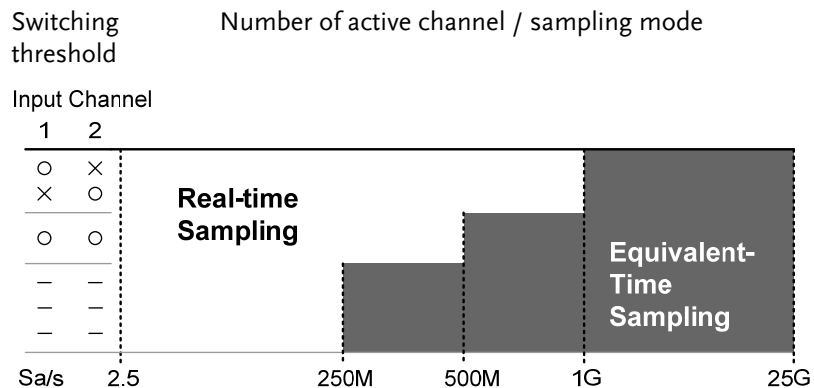

Display

Select waveform drawing (vector/dot)

Panel operation	1. Press the Display key.	
	2. Press <i>Type</i> repeatedly to select the waveform drawing.	
Range	Dots	Only the sampled dots are displayed.
	Vectors	Both the sampled dots and the connecting line are displayed.

Accumulate waveform

Background	Accumulation preserves the old waveform drawings and overwrites new waveforms on top of it. It is useful for observing waveform variation.	
Panel operation	1. Press the Display key.	
	2. Press <i>Accumulate</i> to turn On waveform accumulation.	
	3. To clear the accumulation and start over (refresh), press <i>Refresh</i> .	

Set display contrast

Panel operation	1. Press the Display key.	
-----------------	---------------------------	--

2. Press *Contrast*.



3. Turn the Variable knob left to lower the contrast (dark display) or right to raise the contrast (bright display).



Freeze the waveform (Run/Stop)

For more details about Run/Stop mode, see page39.

Panel operation 1. Press the Run/Stop key. To unfreeze the waveform, press the Run/Stop key again.



2. The waveform and the trigger freezes. The trigger indicator on the top right of the display shows Stop.

Select display grid

Panel operation 1. Press the Display key.



2. Press the grid icon repeatedly to select the grid.

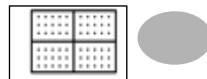

Range



Shows the full grid; X and Y axis for each division.



Shows only the center X and Y frame.



Shows only the outer frame.

Horizontal View

This section describes how to set the horizontal scale, position, and waveform display mode.

Move waveform position horizontally

Panel operation The horizontal position knob moves the waveform left/right.

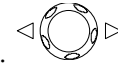

Run mode In Run mode, the waveform keeps its relative position in the memory since the entire memory is continuously captured and updated.

Stop mode In Stop mode, the waveform moves until it reaches the end of the memory.

Select horizontal scale

Select horizontal scale To select the timebase (scale), turn the TIME/DIV knob; left (slow) or right (fast).

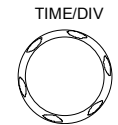

Range 1ns/Div ~ 10s/Div, 1-2-5 increment

The corresponding sampling rate appears on the upper side of the display. The timebase indicator appears on the lower side.

Run mode In Run mode, the waveform size keep their proportion. When the timebase becomes slower, it automatically switches to Scan mode (see the next page).

Stop mode In Stop mode, the memory bar and waveform size changes according to the scale.

Select waveform update mode

Background	The display update mode is switched automatically or manually according to timebase and trigger. The indicator on the bottom left of the display shows the current mode.
Main mode	Updates the whole displayed waveform at once. Automatically selected when the timebase (sampling rate) is fast. Timebase $\leq 50\text{ms/div}$ ($\geq 500\text{Sa/s}$) Trigger all modes
Scan mode	Updates the waveform gradually from the left side of the display to the right. The waveform position is fixed. Automatically selected when the timebase (sampling rate) is slow. Timebase $\geq 100\text{ms/div}$ ($\leq 250\text{Sa/s}$) Trigger Auto mode only Note: When the update mode switches from Main to Scan, GDS-1000 automatically selects the Auto trigger mode. See page64 for trigger details.
Roll mode	Updates and moves the waveform gradually from the right side of the display to the left. Manually selected when the timebase (sampling rate) is slow. Timebase $\geq 250\text{ms/div}$ ($\leq 100\text{Sa/s}$) Trigger all modes

Select Roll mode manually 1. Press the Horizontal menu key. 

2. Press *Roll*. The waveform starts scrolling from the right side of the display. The update mode indicator shows Roll mode. 

Note The Roll mode locks the timebase to be at least 250ms/div (100Sa/s). If faster timebase or sampling rate is required, get out of the Roll mode by pressing *Main*. 

Zoom waveform horizontally

Panel operation/ range 1. Press the Horizontal Menu key. 

2. Press *Window*. 

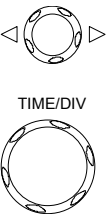
3. Use the horizontal position knob to move the zoom range sideways, and TIME/DIV knob to change the zoom range width. 

The width of the bar in the middle of the display is the actual zoomed area.

Zoom range 1ns ~ 1ms

4. Press *Window Zoom*. The specified range gets zoomed. 

- To go back to the original view, press *Main*.



Show waveform in X-Y mode

Background The X-Y mode compares the voltage of Channel 1 and Channel 2 waveforms in a single display. This mode is useful for observing the phase relationship between the two.

- Connect the signals to Channel 1 (X-axis) and Channel 2 (Y-axis).

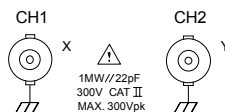

- Make sure both Channel 1 and 2 are activated. Press the Channel key if necessary.

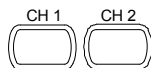

- Press the Horizontal menu key.



- Press XY. The display shows two waveforms in X-Y format; Channel 1 as X-axis, Channel 2 as Y-axis.



- Horizontal Position knob and Time/Div knob are disabled under the X-Y mode. To move the waveform position, use the vertical position knob: Channel 1 knob moves the waveform horizontally, Channel 2 knob vertically.



Vertical View (Channel)

This section describes how to set the vertical scale, position, and coupling mode.

Move waveform position vertically

Panel operation To move the waveform up or down, turn the vertical position knob for each channel. 

As the waveform moves, the vertical position of the cursor appears at the bottom left corner of the display.

Run/Stop mode The waveform can be moved vertically in both Run and Stop mode.

Select vertical scale



Panel operation To change the vertical scale, turn the VOLTS/DIV knob; left (down) or right (up). 



The vertical scale indicator on the bottom left of the display changes accordingly.

Range 2mV/Div ~ 5V/Div, 1-2-5 increments

Stop mode In Stop mode, the vertical scale setting can be changed but the waveform shape stays the same.

Select coupling mode

- Panel operation
1. Press the Channel key. 
 2. Press *Coupling* repeatedly to select the coupling mode. 

- Range
-  DC coupling mode. The whole portion (AC and DC) of the signal appears on the display.
 -  Ground coupling mode. The display shows only the zero voltage level as a horizontal line. This mode is useful for measuring the signal voltage with respect to the ground level.
 -  AC coupling mode. Only the AC portion of the signal appears on the display. This mode is useful for observing AC waveforms mixed with DC signal.

Invert waveform vertically

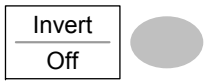
- Panel operation
1. Press the Channel key. 
 2. Press *Invert* to invert the waveform. 

Limit bandwidth

Background Bandwidth limitation puts the input signal into a 20MHz (-3dB) low-pass filter. This function is useful for cutting off high frequency noise to see the clear waveform shape.

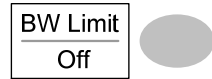
- Panel operation
1. Press the Channel key. 
 2. Press *BW Limit* to turn Off the limitation. 

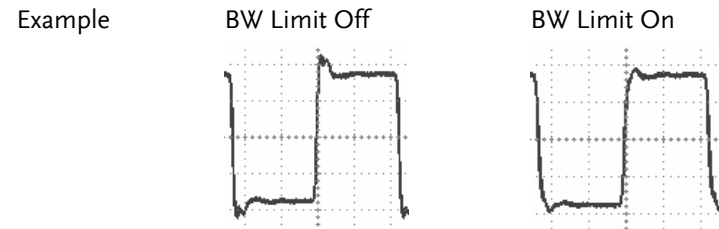

Select probe attenuation level

Background A signal probe has an attenuation switch to lower the original DUT signal level to the oscilloscope input range, if necessary. The probe attenuation selection adjusts the vertical scale so that the voltage level on the display reflects the real value on DUT.

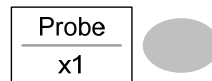
- Panel operation
1. Press the Channel key. 
 2. Press *Probe* repeatedly to select the attenuation level. 

3. The voltage scale in the channel indicator changes accordingly. There is no change in the waveform shape.

Range	x1, x10, x100
-------	---------------

Note	The attenuation factor adds no influence on the real signal. It just changes the voltage scale on the display.
------	--

Trigger

Trigger configures the condition GDS-1000 captures the incoming signal.

Trigger type overview





Edge	Triggers when the signal crosses an amplitude threshold in either positive or negative slope.
Video	Extracts a sync pulse from a video format signal, and triggers on a specific line or field.
Pulse	Triggers when the pulse width of the signal is too narrow or too wide compared to the setting.

Trigger parameter overview

Trigger source	CH1 ~ 4	Channel 1 ~ 4 input signals
	Line	AC mains signal
	Ext	External trigger input signal



Trigger mode	Auto	GDS-1000 generates an internal trigger if there is no trigger event, to make sure waveforms are constantly updated regardless of trigger events. Select this mode especially when viewing rolling waveform at slower timebase.
	Normal	GDS-1000 acquires waveform only when a trigger event occurs.



Single	GDS-1000 acquires waveform once when a trigger event occurs, then stop acquiring. Press the Single key to enter the single mode.	
Auto level	In addition to behaving like the Auto mode, GDS-1000 automatically adjusts the trigger level to the center amplitude of the waveform.	
Video standard (video trigger)	<p>NTSC National Television System Committee</p> <p>PAL Phase Alternative by Line</p> <p>SECAM SEquential Couleur A Memoire</p>	
Sync polarity (video trigger)	<p> Positive polarity</p> <p> Negative polarity</p>	
Video line (video trigger)	<p>Selects the trigger point in the video signal.</p> <p>field 1 or 2</p> <p>line 1~263 for NTSC, 1~313 for PAL/SECAM</p>	
Pulse condition (pulse trigger)	<p>Sets the pulse width (20ns ~ 200us) and the triggering condition.</p> <p>> Longer than = Equal to</p> <p>< Shorter than ≠ Not equal to</p>	
Trigger slope	<p> Triggers on the rising edge.</p> <p> Triggers on the falling edge.</p>	
Trigger coupling	<p>AC Triggers only on the AC component.</p> <p>DC Triggers on AC+DC component.</p>	

Frequency rejection	LF	Puts a high-pass filter and rejects the frequency below 50kHz.
	HF	Puts a low-pass filter and rejects the frequency above 50kHz.
Noise rejection	Rejects noise signal.	

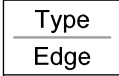
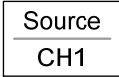

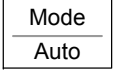

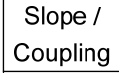

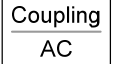

Use edge trigger

- Panel operation
1. Press the Trigger menu key. 
 2. Press *Type* repeatedly to select edge trigger. The edge trigger indicator appears at the bottom of the display. 
 3. Press *Source* repeatedly to select the trigger source. 

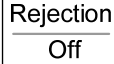

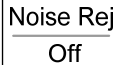

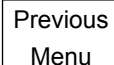

Range Channel 1, 2, Line, Ext
 4. Press *Mode* repeatedly to select the trigger mode. 



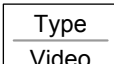

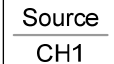
Range Auto, Normal, Auto Level
 5. Press *Slope/coupling* to set trigger slope and coupling. 
 6. Press *Slope* repeatedly to select the trigger slope, which also appears at the bottom of the display. 

Range Rising edge, falling edge





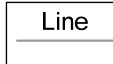

- 7. Press *Coupling* repeatedly to select the trigger coupling.  
Range DC, AC
- 8. Press *Rejection* to select the frequency rejection mode.  
Range LF, HF, Off
- 9. Press *Noise Rej* to turn the noise rejection On/Off.  
Range On, Off
- 10. Press *Previous* menu to go back to the previous menu.  

Use video trigger

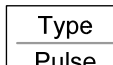
- Panel operation
- 1. Press the Trigger menu key. 
 - 2. Press *Type* repeatedly to select video trigger. The video trigger indicator appears at the bottom of the display.  
 - 3. Press *Source* repeatedly to select the trigger source channel.  
Range Channel 1, 2
 - 4. Press *Standard* repeatedly to select the video standard.  

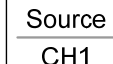
- Range NTSC, PAL, SECAM
- 5. Press *Polarity* repeatedly to select the video signal polarity.  
Range positive, negative
- 6. Press *Line* repeatedly to select the video field line. Use the Variable knob to select the video line.  
VARIABLE 
Field 1, 2
Video line NTSC: 1 ~ 262 (Even), 1 ~ 263 (Odd)
PAL/SECAM: 1 ~ 312 (Even), 1 ~ 313 (Odd)

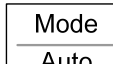
Use pulse width trigger

- Panel operation
- 1. Press the Trigger menu key. 
 - 2. Press *Type* repeatedly to select pulse width trigger. The pulse width trigger indicator appears at the bottom of the display.  
 - 3. Press *Source* repeatedly to select the trigger source.  
Range Channel 1, 2, Line, Ext
 - 4. Press *Mode* repeatedly to select the trigger mode.  

- Range Auto, Normal, Single, Auto Level
5. Press *When* repeatedly to select the pulse condition. Then use the Variable knob to set the pulse width.

When <
20.0ns





Condition > , < , = , ≠

Width 20ns ~ 200us
 6. Press *Slope/Coupling* to set trigger slope and coupling.

Slope /
Coupling



 7. Press *Slope* repeatedly to select the trigger slope, which also appears at the bottom of the display.

Slope





Range Rising edge, falling edge
 8. Press *Coupling* repeatedly to select the trigger coupling.

Coupling
AC



Range DC, AC
 9. Press *Rejection* to select the frequency rejection mode.

Rejection
Off



Range LF, HF, Off
 10. Press *Noise Rej* to turn the noise rejection On/Off.

Noise Rej
Off



Range On, Off
 11. Press *Previous* menu to go back to the previous menu.



Previous
Menu



Use single trigger mode



- Panel operation 1. Press the Single trigger key.  The single trigger mode becomes activated. To deactivate single trigger, press the Single trigger key again.

Force trigger level to 50% of input signal amplitude

- Panel operation 1. Press the trigger Force key.  The trigger level automatically becomes 50% of the input signal amplitude. For manual adjustment, use the trigger Level knob. 

System Setting

View system information

- Panel operation
1. Press the Utility key. 
 2. Press *More*. 
 3. Press *System Info*. The upper half of the display shows the system information in the following format.

System Info.	
--------------	---

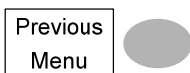
 - Manufacturer
 - Model
 - Serial number
 - Firmware version
 4. Press any other key to go back to the waveform display mode. 

Select menu language

- Parameter
- Language selection differs according to the region to which GDS-1000 is shipped.
- English
 - Chinese (traditional)
 - Chinese (simplified)

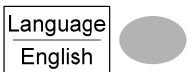
- Panel operation
1. Press the Utility key. 
 2. Press *Language* repeatedly to select the language. 

SAVE/RECALL

File Format/Utility

Display image file format

Format	DSxxxx.bmp or Axxxx.bmp (Windows bitmap format)
Contents	The current display image in 234 x 320 pixels, color format. The background color can be inverted (Ink saver function).

Waveform file format

Format	DSxxxx.csv or Axxxx.csv (Comma-separated values format, can be opened in spreadsheet applications such as Microsoft Excel)	
Waveform type	CH1, 2	Input channel signal
	Math	Math operation result (page48)
Storage location	W1 ~ W15	Waveform file stored in the internal memory. Stored waveforms can be copied to SD card for transfer, or to Ref. A, B for showing on the display (W1 ~ W15 waveforms cannot be directly recalled on the display).

Ref A, B Reference waveform stored in the internal memory, separate from W1 ~ W15. From Ref A/B, waveforms can be recalled directly on the display with amplitude and frequency information. Useful for reference purpose in measurements.

Contents: waveform data

The waveform data can be used for detailed analysis. It consists of horizontal and vertical position of the waveform for the entire memory length.

One division includes 25 points of horizontal and vertical data. The vertical point starts from the center line. The horizontal point starts from the leftmost waveform.

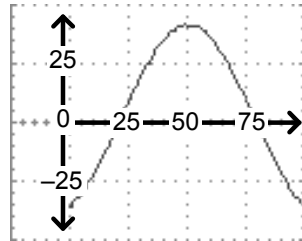

The time length or voltage level which each data point represents differs according to the vertical and horizontal scale. For example:

Vertical scale: 10mV/div (4mV per point)

Horizontal scale: 100us/div (4us per point)

Contents: other data

The following information is also included in the waveform file.







- Memory length
- source channel
- vertical offset
- vertical scale
- coupling mode
- waveform last dot address
- date and time
- trigger level
- vertical position
- time base
- probe attenuation
- horizontal view
- horizontal scale
- sampling period
- sampling mode

Setup file format

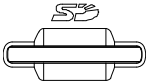

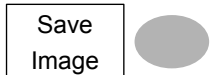
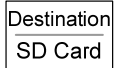
Format	DSxxxx.set or Axxxx.set (proprietary format)	
	The setup file saves or recalls the following setting.	
Contents	Acquire	• mode • memory length
	Cursor	• source channel • cursor on/off • cursor location
	Display	• dots/vectors • accumulation on/off • grid type
	Measure	• item • source channel
	Utility	• hardcopy type • ink saver on/off • menu language
	Horizontal	• display mode • scale • position
	Trigger	• trigger type • source channel • trigger mode • video standard • video polarity • video line • pulse timing • slope/coupling
	Channel (vertical)	• vertical scale • vertical position • coupling mode • invert on/off • bandwidth limit on/off • probe attenuation
	Math	• operation type • source channel • vertical position • unit/div • FFT window

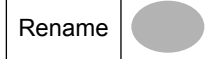

SD card utility

Background For SD card, file deletion, folder creation, file/folder rename are available from the front panel. This feature is not available for internally stored files.

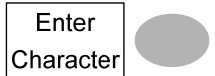
- Panel operation**
1. Connect the card to the card slot. 
 2. Press the Save/Recall key. Select any save or recall functionality, for example SD card destination in Save image function.
 (Example)

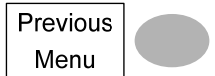
 3. Press *File Utility*. The display shows the SD card contents in root directory.

 4. Use the Variable knob to move the cursor. Press *Select* to go into the folder or go back to the previous directory level.

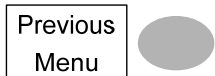

- Create new folder / Rename file or folder**
1. Move the cursor to the file or folder location and press *New Folder* or *Rename*. The file/folder name and the character map appear on the display.



2. Use the Variable knob to move the pointer to the characters. Press *Enter* Character to add a character or *Back Space* to delete a character.



3. When editing is completed, press *Save*. A new folder or a new folder/file name is created.

4. Press *Previous Menu* to go back to the previous menu.

- Delete folder/file**
1. Move the cursor to the folder or file location and press *Delete*. A message appears at the bottom of the display, asking additional confirmation.

 2. If the file/folder still needs to be deleted, press *Delete* again to complete deletion. To cancel deletion, press any other key.

 3. The SD card content is updated. Press *Previous Menu* to go back to Save/Recall menu.

Quick Save (HardCopy)

Background

The Hardcopy key works as a shortcut for saving or printing out information.



Once set, subsequent file saving only requires pressing the Hardcopy key. Hardcopy key can be configured into two operations: save image and save all (image, waveform, setup).

Using the Save/Recall key can also save files but with more configurations. For details, see page79.



Functionality

- Save image (*.bmp) Saves the current display image into an SD card connected to the front or rear panel terminal.
- Save all Saves the following items into an SD card connected to the front or rear panel terminal.
 - Current display image (*.bmp)
 - Current system setup (*.set)
 - Current waveform data (*.csv)
 - Last stored system setup (*.set)
 - Last stored waveform data (*.csv)

Panel operation

1. Connect the SD card to the slot.

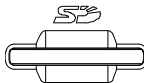

2. Press the Utility key.



3. Press *Hardcopy Menu*.

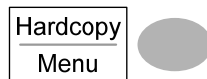

4. Press Function repeatedly to select *Save Image* or *Save All*.

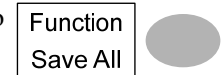

5. To invert the color for the saved or printed display image, press *Ink Saver* and turn On the Ink Saver.



6. To save the image or folder, press the Hardcopy key. The file or folder is saved to the root directory of the SD card.







Save

File type/source/destination

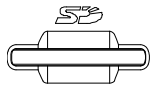
Item	Source	Destination
Panel setup (DSxxxx.set)	<ul style="list-style-type: none"> Front panel settings 	<ul style="list-style-type: none"> Internal memory: S1 ~ S15 External memory: SD card
Waveform data (DSxxxx.csv)	<ul style="list-style-type: none"> Channel 1, 2 Math operation result Reference waveform A, B 	<ul style="list-style-type: none"> Internal memory: Reference waveform A, B, W1 ~ W15 External memory: SD card
Display image (DSxxxx.bmp)	<ul style="list-style-type: none"> Display image 	<ul style="list-style-type: none"> External memory: SD card
Save All	<ul style="list-style-type: none"> Display image (Axxxx.bmp) Waveform data (Axxxx.csv) Front panel settings (Axxxx.set) 	<ul style="list-style-type: none"> External memory: SD card

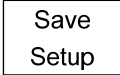
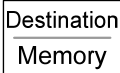
Save panel setting

- Panel operation
- (For saving to an external SD card) Connect the card to the slot. 
 - Press the Save/Recall key twice. 
 - Press *Save Setup*. The display shows the available file destinations. 
 - Press *Destination* repeatedly to select the saved location. Use the Variable knob to change the memory location (S1 ~ S15) or the file name (DSxxxx.set). 

Memory	Internal memory, S1 ~ S15
SD card	External card, no practical limitation on the amount of file. When saved, the setup file is placed in the root directory.
 - Press *Save* to confirm saving. When completed, a message appears at the bottom of the display. 

Note  The file will not be saved if the power is turned Off or SD card is taken out before the message.

File utility To edit SD card contents (create/ delete/ rename files and folders), press *File Utility*. For details, see page75.



Save waveform

Panel operation 1. (For saving to an external SD card) Connect the card to the slot.

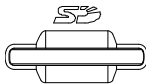

2. Press the Save/Recall key twice.



3. Press *Save Waveform*. The display shows the available source and destination options.



4. Press *Source*. Use the Variable knob to select the source signal.



- CH1 ~ CH2 Channel 1 ~ 2 signal
- Math Math operation result (page48)
- RefA, B Internally stored reference waveforms A, B

5. Press *Destination* repeatedly to select the file destination. Use the Variable knob to select the memory location or file name.



- Memory Internal memory, W1 ~ W15
- SD card External card, no practical limitation on the amount of file. When saved, the waveform file is placed in the root directory.
- Ref Internal reference waveform, A/B

6. Press *Save* to confirm saving. When completed, a message appears at the bottom of the display.

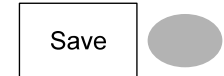

Note The file will not be saved if the power is turned Off or SD card is taken out before the message.

File utility To edit SD card contents (create/ delete/ rename files and folders), press *File Utility*. For details, see page75.

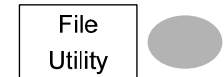

Save display image

Panel operation 1. (For saving to an external SD card) Connect the card to the slot.

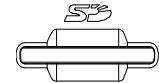

2. Press the Save/Recall key twice.

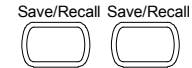

3. Press *Save Image*. The display shows the available file destinations.

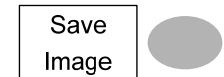

4. Press *Ink Saver* repeatedly to invert the background color (On) or not (Off).

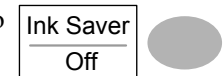

5. Press *Destination*. Use the Variable knob to select the file name.

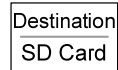

VARIABLE



SD card External card, no practical limitation on the amount of file. When saved, the image file is placed in the root directory.

6. Press *Save* to confirm saving. When completed, a message appears at the bottom of the display.



Note  The file will not be saved if the power is turned Off or SD card is taken out before the message.

File utility To edit SD card contents (create/ delete/ rename files and folders), press *File Utility*. For details, see page75.

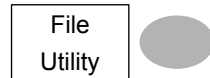

Save All

Panel operation 1. (For saving to an external SD card) Connect the card to the slot.

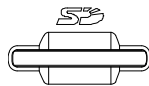

2. Press the Save/Recall key twice.



3. Press *Save All*. The display shows the available file destinations. The following files are saved, contained in a folder.

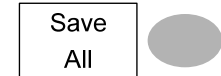

Setup file (Axxx.set)	Two types of setups are saved: the current panel setting and the last internally saved setting (one of S1 ~ S15).
Display image (Axxx.bmp)	The current display image in bitmap format.
Waveform data (Axxx.csv)	Two types of waveform data are saved: the currently active channel data and the last internally saved data (one of W1 ~ W15).

4. Press *Ink Saver* repeatedly to invert the background color (On) or not (Off) for the display image.

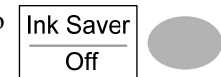

5. Press *Destination*. Use the Variable knob to select the file name.

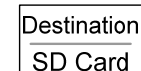

VARIABLE



SD card External card, no practical limitation on the amount of file. When saved, the folder is placed in the root directory.

6. Press *Save* to confirm saving. When completed, a message appears at the bottom of the display.

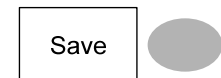



Note

The file will not be saved if the power is turned Off or SD card is taken out before the message.

- Together with the current setup/waveform/image, the last saved waveform file (one from W1 ~ W15) and setup file (one from S1 ~ S15) are also included in the folder.

File utility

To edit SD card contents (create/ delete/ rename files and folders), press *File Utility*. For details, see page75.

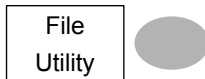

Recall

File type/source/destination

Item	Source	Destination
Default panel setup	<ul style="list-style-type: none"> Factory installed setting 	<ul style="list-style-type: none"> Current front panel
Reference waveform	<ul style="list-style-type: none"> Internal memory: A, B 	<ul style="list-style-type: none"> Current front panel
Panel setup (DSxxx.set)	<ul style="list-style-type: none"> Internal memory: S1 ~ S15 External memory: SD card 	<ul style="list-style-type: none"> Current front panel
Waveform data (DSxxx.csv)	<ul style="list-style-type: none"> Internal memory: W1 ~ W15 External memory: SD card 	<ul style="list-style-type: none"> Reference waveform A, B

Recall default panel setting

- Panel operation 1. Press the Save/Recall key.





2. Press *Default Setup*. The factory installed setting is recalled and replaces the current panel setting.









Setting contents The following is the default setting contents.



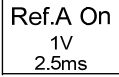

Acquisition Mode: Normal

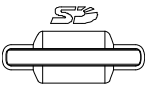

Channel	Scale: 2V/Div Coupling: DC BW limit: Off	CH1: On, CH2/3/4: Off Invert: Off Probe attenuation: x1
Cursor	Source: CH1 Vertical: None	Horizontal: None
Display	Type: Dots Graticule: 	Accumulate: Off
Horizontal	Scale: 2.5us/Div	Mode: Main Timebase
Math	Type: + (Add) Position: 0.00 Div	Channel: CH1+CH2 Unit/Div: 2V
Measure	Source1: CH1	Measurement: Off
Trigger	Type: Edge Mode: Auto Coupling: DC Noise Rejection: Off	Source: Channel1 Slope:  Rejection: Off
Utility	SaveImage, InkSaver Off	

Recall reference waveform on the display





- Panel operation
- The reference waveform must be stored in advance. See page 81 for waveform store details.
 - Press the Save/Recall key. 
 - Press *Display Refs.* The reference waveform display menu appears. 
 - Select the reference waveform from *Ref A* to *Ref B* and press it. The waveform appears on the display and the period and amplitude of the waveform appears in the menu.   
 - To clear the waveform from the display, press *RefA/B* again. 

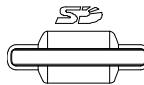

Recall panel setting

- Panel operation
- (For recalling from an external SD card) Connect the card to the slot. 
 - Press the Save/Recall key. 
 - Press *Recall Setup*. The display shows the available file sources. 
 - Press *Source* repeatedly to select the file source, internal or external memory. Use the Variable knob to change the memory.  

Memory	Internal memory, S1 ~ S15
SD card	External card, no practical limitation on the amount of file. The setup file must be placed in the root directory to be recognized.
 - Press *Recall* to confirm recalling. When completed, a message appears at the bottom of the display. 
- Note  The file will not be saved if the power is turned Off or SD card is taken out before the message.
-
- File utility
- To edit SD card contents (create/ delete/ rename files and folders), press *File Utility*. For details, see page75. 

Recall waveform

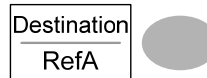
- Panel operation
- (For recalling from an external SD card) Connect the card to the slot. 
 - Press the Save/Recall key. 
 - Press *Recall Waveform*. The display shows the available source and destination options. 
 - Press *Source* repeatedly to select the file source, internal memory or external SD card. Use the Variable knob to change the memory location (W1 ~ W15) or the file name (DSxxxx.csv).  

Memory	Internal memory, W1 ~ W15
SD card	External flash drive, no practical limitation on the amount of file. The waveform file must be placed in the root directory to be recognized.
 - Press *Destination*. Use the Variable knob to select the memory location.  

RefA, B	Internally stored reference waveforms A, B
---------	--

- Press *Recall* to confirm recalling. When completed, a message appears at the bottom of the display.



Note  The file will not be saved if the power is turned Off or SD card is taken out before the message.

File utility





To edit SD card contents (create/ delete/ rename files and folders), press *File Utility*. For details, see page75.



MAINTENANCE

Two types of maintenance operations are available: calibrate vertical resolution, and compensate the probe. Run these operations when using GDS-1000 in a new environment.

Vertical Resolution Calibration

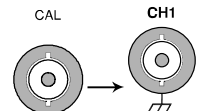
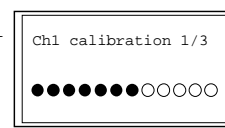
- Panel operation
- Press the Utility key. 
 - Press *More*. 
 - Press *Self Cal Menu*. 
 - Press *Vertical*. A message appears at the bottom of the display. 
 - Connect the calibration signal from the rear panel CAL out to Channel1 input. 
 - Press the specified key and start calibration.
 - The calibration for Channel1 starts and ends automatically in less than 5 minutes. 

- When finished, connect the calibration signal to Channel2 and repeat the procedure.
- When the calibration for all channels are completed, the display goes back the default state.



Probe Compensation

Panel operation

- Connect the probe between Channel1 input and the probe compensation output (2Vp-p, 1kHz square wave) on the front panel. Set the probe attenuation to x10.

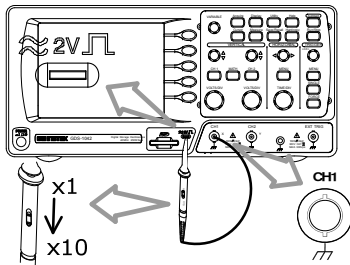

- Press the Utility key.
- Press *ProbeComp*.
- Press *Wavetype* repeatedly to select the standard square wave.

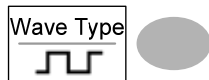

- Press the Autoset key. The compensation signal appears on the display.



- Press the Display key, then *Type* to select the vector waveform.

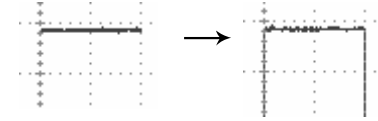
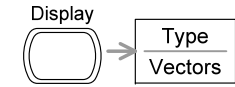

- Turn the adjustment point on the probe until the signal edge becomes sharp.

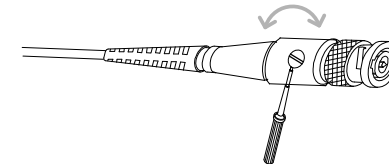
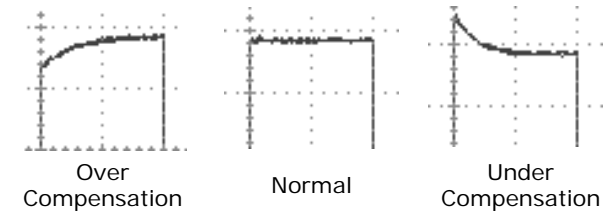

FAQ

- The input signal does not appear on the display.
- I want to remove some contents from the display.
- The waveform does not update (frozen).
- The probe waveform is distorted.
- Autoset does not catch the signal well.
- I want to clean up the cluttered panel settings.
- The accuracy does not match the specification.
- The SD card slot does not accept my card.

The input signal does not appear on the display.

Make sure you have activated the channel by pressing the CH key.

I want to remove some contents from the display.

To clear automatic measurement result, press the Measure key twice, then Press Indication (Off). See page43 for details.

To clear FFT result, press the Math key twice. See page48 for details.

To clear Help result, press the Help key again. See page36 for details.

The waveform does not update (frozen).

Press the Run/Stop key to unfreeze the waveform. See page39 for details.

If this does not help, the trigger mode might be set to Single. Press the Single trigger key again. See page64 for trigger setting details.

The probe waveform is distorted.

You might need to compensate the probe. For details, see page93. Note that the frequency accuracy and duty factor are not specified for probe compensation waveform and therefore it should not be used for other reference purpose.

Autoset does not catch the signal well.

Autoset function cannot catch signals under 30mV or 30Hz. Please use the manual operation. See page38 for Autoset details.

I want to clean up the cluttered panel settings.

Recall the default settings by pressing Save/Recall key→Default Setting. For default setting contents, see page35.

The saved display image is too dark on the background.

Use the Inksaver function which reverses the background color. For details, see page82.

The accuracy does not match the specification.

Make sure the device is powered On for at least 30 minutes, within +20°C~+30°C. This is necessary to stabilize the unit to match the specification.

The SD card slot does not accept my card.

Make sure it is a standard SD card. MMC and SDHC are not supported.

For more information, contact your local dealer or GWInstek at www.gwinstek.com.tw / marketing@goodwill.com.tw.

APPENDIX

Fuse Replacement

- Step 1. Take off the power cord and remove the fuse socket using a minus driver.

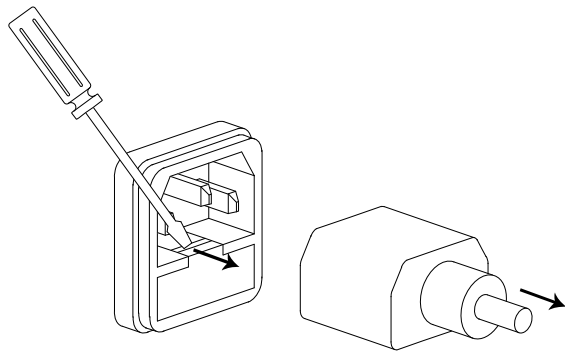

2. Replace the fuse in the holder.

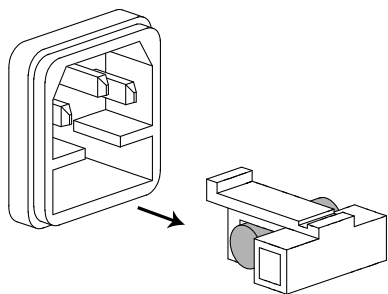

Rating T1A, 250V

GDS-1000 Specification

The specifications apply when GDS-1000 is powered on for at least 30 minutes under +20°C~+30°C.

Model-specific

GDS-1022	Bandwidth (-3dB)	DC coupling: DC ~ 25MHz AC coupling: 10Hz ~ 25MHz
	Bandwidth Limit	None
	Trigger Sensitivity	Approx. 0.5div or 5mV
	External Trigger Sensitivity	~ 50mV
GDS-1042	Bandwidth (-3dB)	DC coupling: DC ~ 40MHz AC coupling: 10Hz ~ 40MHz
	Bandwidth Limit	None
	Trigger Sensitivity	0.5div or 5mV (DC ~ 25MHz) 1.5div or 15mV (25MHz~40MHz)
	External Trigger Sensitivity	~ 50mV
GDS-1062	Bandwidth (-3dB)	DC coupling: DC ~ 60MHz AC coupling: 10Hz ~ 60MHz
	Bandwidth Limit	20MHz (-3dB)
	Trigger Sensitivity	0.5div or 5mV (DC ~ 25MHz) 1.5div or 15mV (25MHz~60MHz)
	External Trigger Sensitivity	~ 50mV (DC~25MHz) ~ 100mV (25MHz~60MHz)
GDS-1102	Bandwidth (-3dB)	DC coupling: DC ~ 100MHz AC coupling: 10Hz ~ 100MHz
	Bandwidth Limit	20MHz (-3dB)
	Trigger Sensitivity	0.5div or 5mV (DC ~ 25MHz) 1.5div or 15mV (25MHz~100MHz)
	External Trigger Sensitivity	~ 50mV (DC~25MHz) ~ 100mV (25MHz~100MHz)
	Rise Time	< 3.5ns

Common

Vertical	Sensitivity	2mV/div~5V/Div (1-2-5 increments)	
	Accuracy	± (3% x Readout +0.1div + 1mV)	
	Bandwidth	See model-specific specifications	
	Rise Time	See model-specific specifications	
	Input Coupling	AC, DC, Ground	
	Input Impedance	1MΩ±2%, ~16pF	
	Polarity	Normal & Invert	
	Maximum Input	300V (DC+AC peak), CAT II	
	Math Operation	+, -, FFT	
	Offset Range	2mV/div~50mV/div: ±0.4V	
		10mV/div~500mV/div: ±4V	
		1V/div~5V/div: ±40V	
	Trigger	Sources	CH1, CH2, Line, EXT
Modes		Auto-Level, Auto, Normal, Single, TV, Edge, Pulse Width, Time-Delay, Event-Delay	
		Time Delay Range	100ns to 1.3ms
Event Delay Range		2 to 65000	
Start Trigger Level		±12V, adjustable (for USER mode)	
Coupling		AC, DC, LFrej, HFrej, Noise rej	
Sensitivity		See model-specific specifications	
TV Trigger		0.5div of synchronization signal	
Sensitivity			
External trigger		Range	DC: ±15V, AC: ±2V
		Sensitivity	See model-specific specifications
		Input Impedance	1MΩ±2%, ~16pF
		Maximum Input	300V (DC+AC peak), CATII
Horizontal	Range	1ns/div~10s/div, 1-2-5 increment	
	Modes	Main, Window, Window Zoom, Roll, X-Y	
	Accuracy	±0.01%	
	Pre-Trigger	10 div maximum	
	Post-Trigger	1000 div	
X-Y Mode	X-Axis Input	Channel 1	
	Y-Axis Input	Channel 2	
	Phase Shift	±3° at 100kHz	
Signal Acquisition	Real-Time	250M Sa/s maximum	
	Equivalent	25G Sa/s maximum	
	Vertical	8 bits	
	Resolution		
	Record Length	4k points	

	Single shot Acquisition	4k points record, 25MHz bandwidth
	Peak Detection	Normal, Peak Detect, Average
	Average	10ns (500ns/div ~ 10s/div)
		2, 4, 8, 16, 32, 64, 128, 256
Cursors and Measurement	Voltage	Vpp, Vamp, Vavg, Vrms, Vhi, Vlo, Vmax, Vmin, Rise Preshoot/ Overshoot, Fall Preshoot/ Overshoot
	Time	Freq, Period, Rise Time, Fall Time, + Width, - Width, Duty Cycle
	Cursors	Voltage difference (ΔV) and Time difference (ΔT) between cursors Reciprocal of ΔT in Hertz (1/ΔT)
Auto Counter	Resolution: 6 digits, Accuracy: ±2%	Signal source: All available trigger source except the Video trigger
Trigger Frequency Counter	Resolution	6 digits
	Frequency Range	20Hz minimum to rated bandwidth
	Accuracy	±2%
Control Panel Function	Signal Source	All trigger source except the Video trigger
	Autoset	Automatically adjust Vertical Volt/div, Horizontal Time/div, and Trigger level
Display	Save/Recall	Up to 15 sets of measurement conditions and waveforms
	LCD	5.6 inch, TFT, brightness adjustable
Interface	Resolution (dots)	234 (Vertical) x 320 (Horizontal)
	Graticule	8 x 10 divisions
	Display Contrast	Adjustable
Probe Compensation	USB Slave Connector	USB1.1 & 2.0 full speed compatible (printers and flash disk not supported)
	SD Card Slot	Image (BMP) and waveform data (CSV)
	Frequency range	1kHz ~ 100kHz adjustable, 1kHz step
Signal	Duty cycle	5% ~ 95% adjustable, 5% step
	Amplitude	2Vpp±3%
Power Source	Line Voltage	100V~240V AC, 47Hz~63Hz
	Power Consumption	18W, 25VA maximum
	Fuse Rating	1A slow, 250V
Operation Environment	Ambient temperature	0 ~ 50°C
Storage Environment	Relative humidity	≤ 80% @35°C
	Ambient temperature	-20 ~ 70°C
Dimensions	Relative humidity	≤ 80% @70°C
Weight	Dimensions	140 (D) x 142 (H) x 310 (W) mm
	Weight	Approx. 2.5kg

Declaration of Conformity

We

GOOD WILL INSTRUMENT CO., LTD.

(1) No.7-1, Jhongsing Rd., Tucheng City, Taipei County, Taiwan

(2) No. 69, Lu San Road, Suzhou City (Xin Qu), Jiangsu Sheng, China

declare, that the below mentioned product

Type of Product: Digital Storage Oscilloscope

Model Number: GDS-1022, GDS-1042, GDS-1062, GDS-1102

are herewith confirmed to comply with the requirements set out in the Council Directive on the Approximation of the Law of Member States relating to Electromagnetic Compatibility (89/336/EEC, 92/31/EEC, 93/68/EEC) and Low Voltage Directive (73/23/EEC, 93/68/EEC).

For the evaluation regarding the Electromagnetic Compatibility and Low Voltage Directive, the following standards were applied:

© **EMC**

EN 61326-1: Electrical equipment for measurement, control and laboratory use -- EMC requirements (1997 + A1:1998 + A2:2001 + A3:2003)	
Conducted Emission	Electrical Fast Transients
Radiated Emission	EN 61000-4-4: 2004
EN 55011: Class A 1998 + A1:1999 + A2:2002	
Current Harmonics	Surge Immunity
EN 61000-3-2: 2000 + A2:2005	EN 61000-4-5: 1995 + A1:2001
Voltage Fluctuations	Conducted Susceptibility
EN 61000-3-3: 1995 + A1:2001 + A2:2005	EN 61000-4-6: 1996 + A1:2001
Electrostatic Discharge	Power Frequency Magnetic Field
EN 61000-4-2: 1995 + A1:1998 + A2:2001	EN 61000-4-8: 1993 + A1:2001
Radiated Immunity	Voltage Dip/ Interruption
EN 61000-4-3: 2002 + A1:2002	EN 61000-4-11: 2004

© **Safety**

Low Voltage Equipment Directive 73/23/EEC & amended by 93/68/EEC
Safety Requirements
IEC/EN 61010-1: 2001